

MK™ Dispensing Solutions



2-COMPONENT DISPENSERS

 medmix

INDUSTRY 

MK™ SYSTEM OVERVIEW

The MK Manual Dispenser product ranges

Pages 10 to 31



The MK Battery Dispenser product ranges

Pages 32 to 59

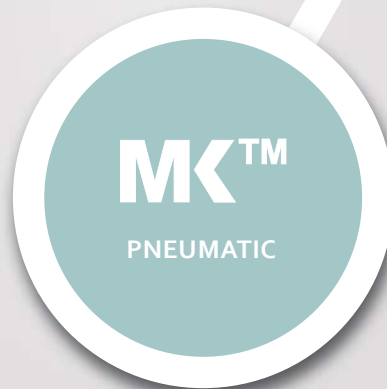

The MK Pneumatic Dispenser product ranges

Pages 60 to 89











All of our MK™ dispensers may be recognized by their well-known unique and pleasing visual appearances.





2-COMPONENT DISPENSERS

PRODUCT RANGES

SMART DISPENSING FOR ALL APPLICATIONS.

	Name/ Description	Cartridge/ Sachet/Bulk	Cartridge / Sachet Capacity	Cartridge Ratio	Maximum Thrust	Mechanical Advantage Ratio	Material Viscosity	Pages
Manual Dispensers								
	H8 XM	cartridge	50 mL (1.8 oz)	1:1, 2:1	1.3 kN	12:1	low	10–11
	H236 M H236 M-410	cartridge	200 mL (7 oz)	1:1, 2:1, 4:1, 10:1	5 kN	26:1	low/medium	12–13
	H248 H248 M	cartridge	200 mL (7 oz)	1:1	4 kN	18:1	medium	14–15
	H297 MN	cartridge	330 mL (11.6 oz)	10:1	5 kN	26:1	medium	16–17
	H297 iMN	cartridge	330 mL (11.6 oz)	10:1	5 kN	26:1	medium	18–19
	H285 sM H285 S	cartridge	380 mL (13.4 oz)	10:1 5:1	5 kN	26:1	medium	20–21
	H260 H260 M	cartridge	350 mL (12.3 oz)	10:1	5 kN	26:1	medium	22–23
	H244 s	cartridge	385 mL (13.6 oz)	3:1	5 kN	26:1	high	24–25



	Name/ Description	Cartridge/ Sachet/Bulk	Cartridge / Sachet Capacity	Cartridge Ratio	Maximum Thrust	Mechanical Advantage Ratio	Material Viscosity	Pages
	H288 H288 M H288 N	cartridge	600 mL (21.1 oz)	1:1	5 kN	26:1	medium	26–27
	H293 H293 PM	cartridge	450 mL (15.8 oz) 600 mL (21.1 oz)	2:1 1:1	5 kN	26:1	medium/high	28–29
	H239	cartridge	900 mL (31.7 oz)	2:1	5 kN	26:1	high	30–31

2-COMPONENT DISPENSERS

PRODUCT RANGES

SMART DISPENSING FOR ALL APPLICATIONS.





Name/ Description	Cartridge/ Sachet/Bulk	Cartridge / Sachet Capacity	Cartridge Ratio	Maximum Thrust	Voltage	Material Viscosity	Pages	
Battery Dispensers								
	B948 M	cartridge	200 ml (7 oz)	1:1	4 kN	18 V	medium	32–33
	B983 M	cartridge	400 mL (14 oz)	1:1	5 kN	18 V	high	34–35
	B983 M-2:1	cartridge	400 mL (14 oz)	2:1	5 kN	18 V	high	36–37
	B938 M	cartridge	400 mL (14 oz)	4:1	5 kN	18 V	high	38–39
	B978 M	cartridge	400 mL (14 oz)	10:1	5 kN	18 V	high	40–41
	B944 K	cartridge	385 mL (13.5 oz) 585 mL (20.6 oz)	3:1	2.7 kN	18 V	low/medium	42–43
	B960 M	cartridge	350 mL (12.3 oz)	10:1	2.8 kN	18 V	low/medium	44–45
	B985 M	cartridge	380 mL (13.4 oz)	10:1	2.75 kN	18 V	low/medium	46–47
	B959 M	cartridge	450 mL (15.8 oz)	2:1	4.45 kN	18 V	medium/high	48–49
	B988 M	cartridge	600 mL (21.1 oz)	1:1	4.73 kN	18 V	medium	50–51
	B996 M	cartridge	750 ml (26.4 oz)	4:1	5 kN	18 V	medium	52–53





	Name/ Description	Cartridge/ Sachet/Bulk	Cartridge / Sachet Capacity	Cartridge Ratio	Maximum Thrust	Voltage	Material Viscosity	Pages
	B998 M	cartridge	825 mL (29 oz)	10:1	5 kN	18 V	medium	54–55
	B939 M	cartridge	900 ml (31.6 oz)	2:1	5 kN	18 V	medium/high	56–57
	B999 M	cartridge	1500 mL (52.8 oz)	1:1	5 kN	18 V	medium	58–59

2-COMPONENT DISPENSERS

PRODUCT RANGES

SMART DISPENSING FOR ALL APPLICATIONS.

Name/ Description	Cartridge/ Sachet/Bulk	Cartridge / Sachet Capacity	Cartridge Ratio	Maximum Thrust	Pneumatic Pressure	Material Viscosity	Pages	
Pneumatic Dispensers								
	TS408 HM-101	cartridge	50 mL (1.8 oz)	10:1	1.3 kN	8 bar / 116 psi	low	60–61
	TS408 MY-8	cartridge	50 mL (1.8 oz)	1:1, 2:1, 4:1, 10:1	1.3 kN	8 bar / 116 psi	low	62–63
	TS408M-75	cartridge	75 mL (1.8 oz)	1:1, 2:1, 4:1, 10:1	1.3 kN	8 bar / 116 psi	low	64–65
	TS408 EM	cartridge	50 mL (1.8 oz)	1:1, 2:1, 3:2	1.3 kN	8 bar / 116 psi	low	66–67
	TS408 BM	cartridge	50 mL (1.8 oz)	4:1, 10:1	1.3 kN	8 bar / 116 psi	low	68–69
	TS483 XM	cartridge	400 mL (14 oz)	1:1	4 kN	8 bar / 116 psi	medium/high	70–71
	TS483 LXM	cartridge	400 mL (14 oz)	1:1	2.7 kN	8 bar / 116 psi	medium	72–73
	TS459 LXS	cartridge	450 mL (15.8 oz)	2:1	2.7 kN	8 bar / 116 psi	medium	74–75
	TS459 XM	cartridge	450 mL (15.8 oz)	2:1	4 kN	8 bar / 116 psi	medium	76–77
	TS444 KX	cartridge	365 mL (12.8 oz) 385 mL (13.5 oz) 585 mL (20.6 oz) 600 mL (21.1 oz) ecopaCC	3:1	4 kN	8 bar / 116 psi	medium	78–79
	TS447 X-625	cartridge	580 mL (20.4 oz)	1:1	6.25 kN	8 bar / 116 psi	high	80–81

	Name/ Description	Cartridge/ Sachet/Bulk	Cartridge / Sachet Capacity	Cartridge Ratio	Maximum Thrust	Pneumatic Pressure	Material Viscosity	Pages
	TS488 X	cartridge	600 mL (21.1 oz)	1:1	4 kN	8 bar / 116 psi	medium	82–83
	TS488 XM	cartridge	600 mL (21.1 oz)	1:1	4 kN	8 bar / 116 psi	medium	84–85
	TS493 X TS493 XT	cartridge	600 mL (21.1 oz)	1:1	4 kN	8 bar / 116 psi	medium	86–87
	TS471	cartridge	1400 mL (49.3 oz)	3:1	8.3 kN	8 bar / 116 psi	medium/high	88–89

H8 XM

50 ML CARTRIDGE DISPENSER



Cartridge holder and handle
in reinforced nylon

Balanced dispenser
for precise working

Trigger
integrated brake release

Model shown: H8 XM 50 mL

FEATURES

- Anti-drip, trigger integrated brake release
- Reinforced nylon frame and handle
- High gearing ratio
- One hand operation
- Customization possible

BENEFITS

- Fast, reliable clean application
- Easy handling for precise working
- Long life technology
- Lightweight and compact
- Customer labelling

APPLICATIONS

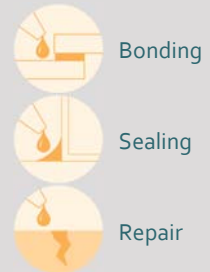

PRODUCT BY RANGE



H8 XM

THE H8 XM 2-COMPONENT MANUAL DISPENSER HAS A LIGHT-WEIGHT COMPACT DESIGN WHILE THE HIGH GEARING RATIO OFFERS LONG LIFE TECHNOLOGY.

SPECIFICATIONS

- Lightweight: 0.41 kg / 0.9 lbs
- Dispenser Length: 181 mm / 7.13 in
- Maximum Thrust: 1.3 kN (stroke 5.4 mm)
- Handle Material: Reinforced Nylon
- Cartridge Holder Material: Reinforced Nylon
- Cartridge Capacity: 50 mL (1.8 oz)
- Cartridge Ratios: 1:1, 2:1
- Mechanical Advantage Ratio: 12:1
- Viscosity: Low/Medium
- Standard Color: Black/Red
- Customized versions on demand

DIMENSIONS

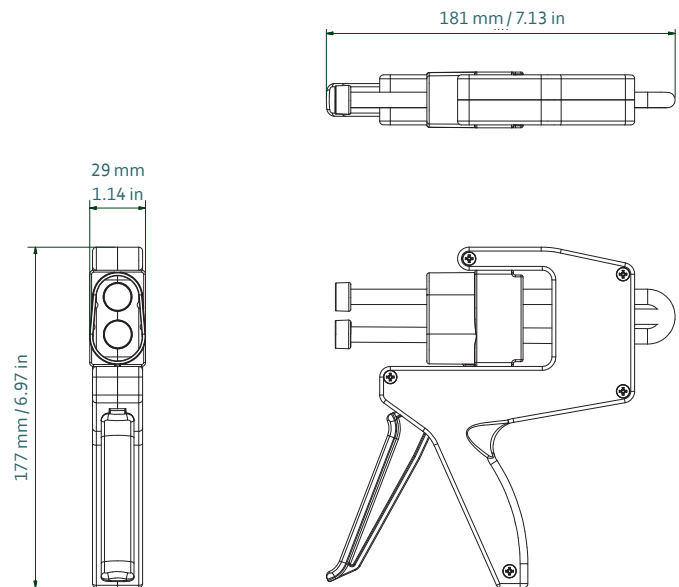

Part number	Article number	Packaging
DM2K 50-12-r12-001	151744	1 per Box, 50 per master carton

MATCHING MIXPAC™ SIDE-BY-SIDE CARTRIDGES



A-System
50 mL / 1:1 PP/PA



A-System
50 mL / 2:1 PP/PA



B-System
50 mL / 1:1 PP/PA



B-System
50 mL / 2:1 PP/PA

COMPATIBLE CARTRIDGES

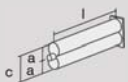

Rectangular Flange Cartridge
50 mL / 1:1 PP/PBT



Rectangular Flange Cartridge
50 mL / 2:1 PP/PBT

1:1	mm	inch
l	99.7	3.93
a	Ø 21.0	Ø 0.83
c	46.0	1.81

2:1	mm	inch
l	108.5	4.27
a	Ø 25.0	Ø 0.89
b	Ø 18.0	Ø 0.71
c	46.0	1.81

CONVERSION KITS

MATCHING ACCESSORIES

H236 M / H236 M-410

200 ML CARTRIDGE DISPENSER

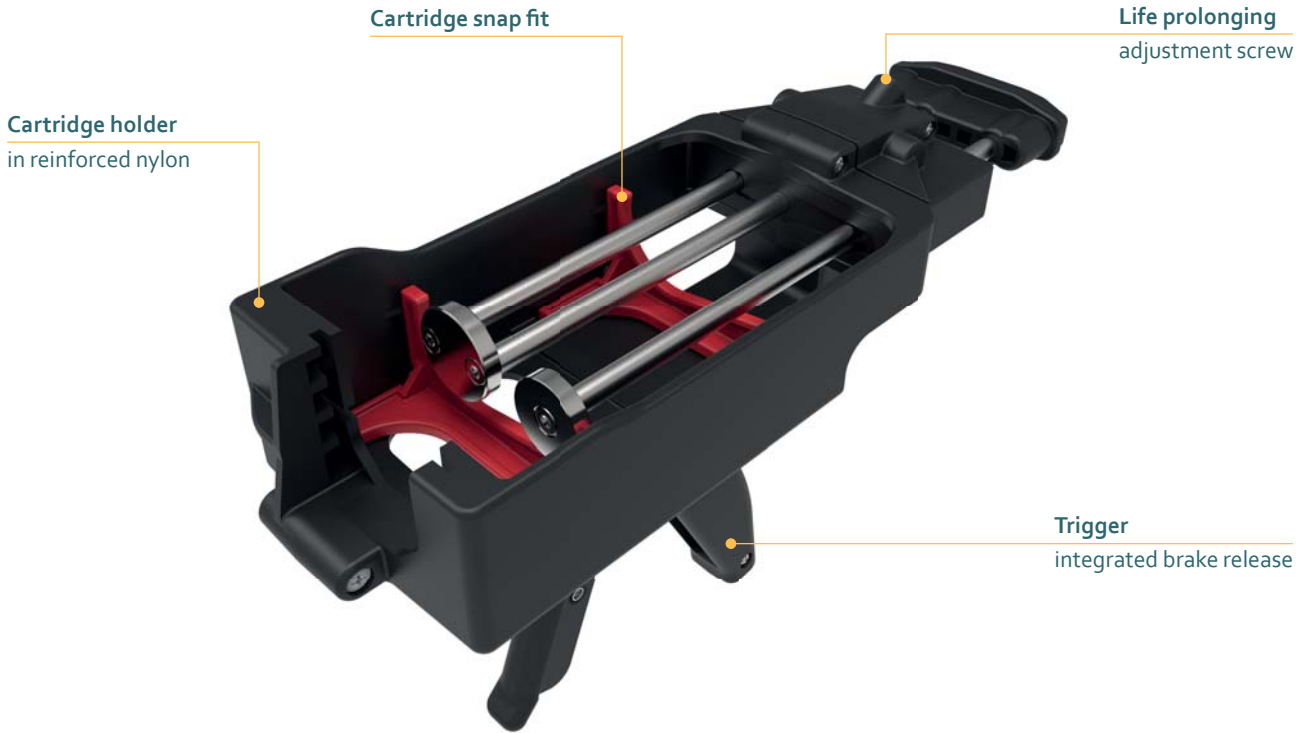

Model shown: H236 M 200 mL

FEATURES

- Fast, reliable and easy handling
- Cartridge positioning and fixation snap fit
- Life prolonging adjustment screw
- Lightweight reinforced nylon frame
- Customization possible

BENEFITS

- For precise working
- Easy cartridge ratio shift
- No loss of performance – anti-wear
- One hand operation
- Customer labelling

APPLICATIONS



Bonding



Sealing



Repair



Shimming

PRODUCT BY RANGE

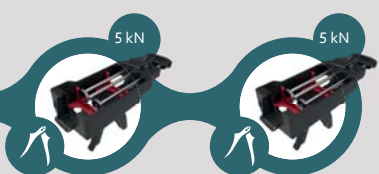

H236 M

H236 M-410

H236 M/M-410 2-COMPONENT MANUAL DISPENSER WITH LIFE PROLONGING ANTI-WEAR ADJUSTMENT SCREW AND EASY CARTRIDGE POSITIONING AND FIXATION SNAP FIT.

SPECIFICATIONS

- Lightweight: 1.07 kg / 2.3 lbs
- Cartridge Holder Length: 157 mm / 6.2 in
- Maximum Thrust: 5 kN (stroke 3.5 mm)
- Handle Material: Reinforced Nylon
- Cartridge Holder Material: Reinforced Nylon
- Cartridge Capacity: 200 mL (7 oz)
- Cartridge Ratios: 1:1, 2:1; 4:1, 10:1
- Mechanical Advantage Ratio: 26:1
- Viscosity: Low/Medium
- Standard Color: Black/Red
- Customized versions on demand

DIMENSIONS

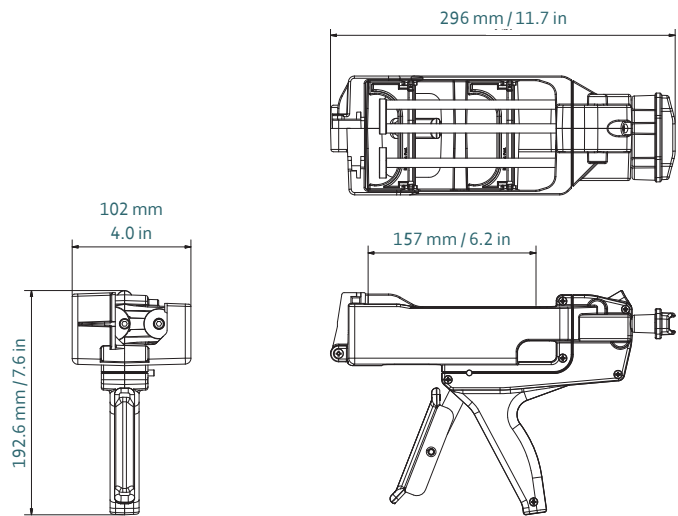

Part number	Article number	Packaging
DM2K 200-12-r26-001	151746 (1:1, 2:1)	1/10 units per box
DM2K 200-410-r26-01	151745 (4:1, 10:1)	1/10 units per box

MATCHING MIXPAC™ SIDE-BY-SIDE CARTRIDGES



C-System/F-System
200 mL / 1:1 PP/PA



C-System/F-System
200 mL / 2:1 PP/PA



C-System/F-System
200 mL / 4:1 PP



C-System/F-System
200 mL / 10:1 PP/PA

COMPATIBLE CARTRIDGES

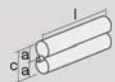

Plastic Cartridge
200 mL / 1:1 PP

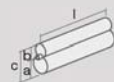

Plastic Cartridge
200 mL / 2:1 PP

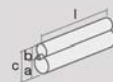

Plastic Cartridge
200 mL / 4:1 PP/PBT

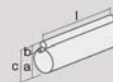

Plastic Cartridge
200 mL / 10:1 PP/PBT

1:1	mm	inch
l	148.0	5.83
a	Ø 37.0	Ø 1.46
c	79.0	3.11

2:1	mm	inch
l	148.0	5.83
a	Ø 50.0	Ø 1.97
b	Ø 31.0	Ø 1.22
c	81.0	3.19

4:1	mm	inch
l	148.0	5.83
a	Ø 49.0	Ø 1.93
b	Ø 25.0	Ø 0.98
c	77.0	3.03

10:1	mm	inch
l	147.0	5.79
a	Ø 55.0	Ø 2.17
b	Ø 19.0	Ø 0.75
c	78.0	3.07

CONVERSION KITS

MATCHING ACCESSORIES

H248 / H248 M

200 ML CARTRIDGE DISPENSER



Model shown: H248 200 mL

FEATURES

- Anti-drip and trigger integrated brake release
- Life prolonging adjustment screw
- Reinforced nylon barrel housing
- High gearing ratio
- U-opening with cartridge snap fit
- Customization possible

BENEFITS

- Fast, reliable and clean application
- No loss of performance – anti-wear
- Long life technology
- Easy handling for precise working
- Easy insertion and removal of cartridges
- Customer labelling

APPLICATIONS



Chemical
Anchoring

PRODUCT BY RANGE

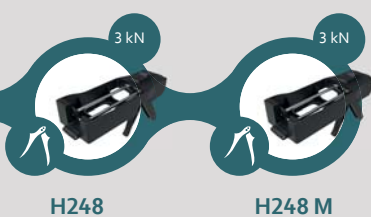

THE H248 2-COMPONENT MANUAL DISPENSER WITH REINFORCED U-OPENING BARREL AND HIGH GEARING RATIO OFFERS EASY HANDLING FOR PRECISE WORKING.

SPECIFICATIONS

- Lightweight: 0.82 kg / 1.8 lbs
- Cartridge Holder Length: 158 mm / 6.2 in
- Maximum Thrust: 3 kN (stroke 5 mm)
- Handle Material: Reinforced Nylon
- Cartridge Holder Material: Reinforced Nylon
- Cartridge Capacity: 200 mL (7 oz)
- Cartridge Ratio: 1:1
- Mechanical Advantage Ratio: 18:1
- Viscosity: Medium
- Standard Color: Black
- Customized versions on demand

DIMENSIONS

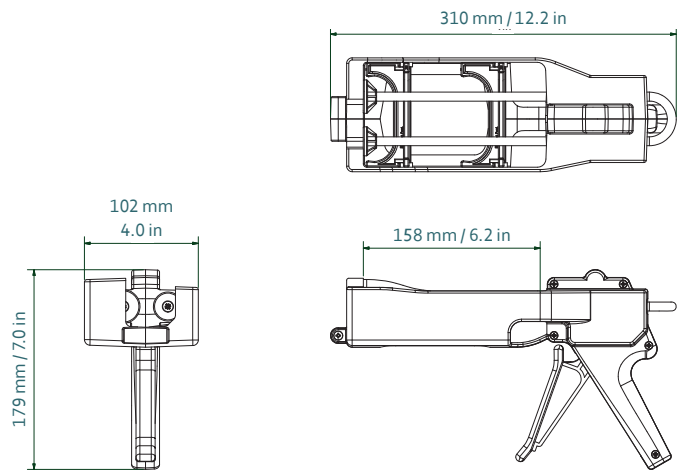

Part number	Article number	Packaging
DM2K 200-01-r18-201	154249 (H248) (For use with compatible cartridges)	10 per Box
DM2K 200-01-r18-101	151750 (H248M) (For use with MIXPAC cartridges)	10 per Box

MATCHING MIXPAC™ CARTRIDGES



C-System/F-System
200 mL / 1:1 PP/PA

COMPATIBLE SIDE-BY-SIDE CARTRIDGES

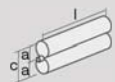

Plastic Cartridge
200 mL / 1:1 PP

1:1	mm	inch
l	148.0	5.83
a	Ø 37.0	Ø 1.46
c	79.0	3.11

CONVERSION KITS

MATCHING ACCESSORIES

H297 MN

330 ML CARTRIDGE DISPENSER



Model shown: H297 MN 330 mL

FEATURES

- Anti-drip and trigger integrated brake release
- Life prolonging adjustment screw
- Reinforced nylon barrel housing
- High gearing ratio
- U-opening with cartridge snap fit
- Customization possible

BENEFITS

- Fast, reliable and clean application
- No loss of performance – anti-wear
- Long life technology
- Easy handling for precise working
- Easy insertion and removal of cartridges
- Customer labelling

APPLICATIONS



PRODUCT BY RANGE



THE H297 MN 2-COMPONENT MANUAL DISPENSER'S ANTI-DRIP AND TRIGGER INTEGRATED BRAKE RELEASE DELIVERS A RELIABLE AND FAST APPLICATION.

SPECIFICATIONS

- Lightweight: 0.8 kg / 1.8 lbs
- Cartridge Holder Length: 250 mm / 9.8 in
- Maximum Thrust: 5 kN (stroke 3.5 mm)
- Handle Material: Reinforced Nylon
- Cartridge Holder Material: Reinforced Nylon
- Cartridge Capacity: 330 mL (11.6 oz)
- Cartridge Ratio: 10:1
- Mechanical Advantage Ratio: 26:1
- Viscosity: Medium
- Standard Color: Black
- Customized versions on demand

DIMENSIONS

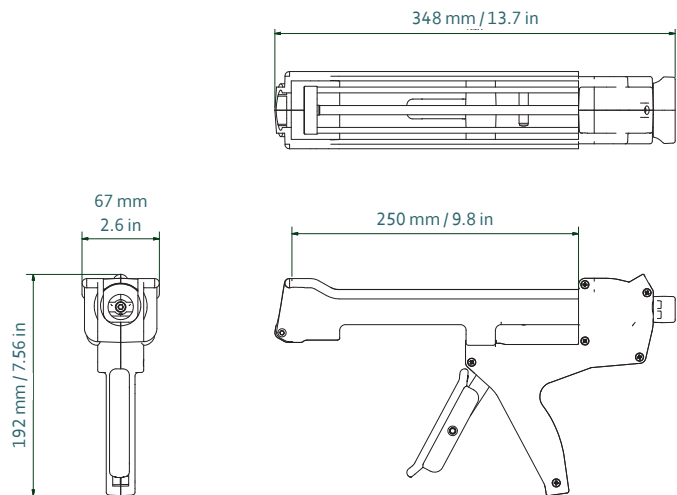

Part number	Article number	Packaging
DM2K 330-10-r26-001	151769	10 per Box

MATCHING MIXPAC™ COAXIAL CARTRIDGES

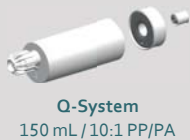

COMPATIBLE COAXIAL CARTRIDGES



	mm	inch
l	117.0	4.6
a	Ø 50.0	Ø 1.9
b	Ø 14.3	Ø 0.5

	mm	inch
l	218.0	8.58
a	Ø 50.0	Ø 1.97
b	Ø 14.2	Ø 0.5

CONVERSION KITS

MATCHING ACCESSORIES

H297 IMN

330 ML CARTRIDGE DISPENSER



Model shown: H297 iMN 330 mL

FEATURES

- Anti-drip and trigger integrated brake release
- Life prolonging adjustment screw
- Reinforced nylon barrel housing
- High gearing ratio
- U-opening with cartridge snap fit
- Customization possible

BENEFITS

- Fast, reliable and clean application
- No loss of performance – anti-wear
- Long life technology
- Easy handling for precise working
- Easy insertion and removal of cartridges
- Customer labelling

APPLICATIONS



PRODUCT BY RANGE



THE H297 IMN 2-COMPONENT MANUAL DISPENSER OFFERS EASY HANDLING FOR PRECISE WORKING, WHILE THE INDICATOR ROD SHOWS YOU HOW MUCH MATERIAL IS LEFT IN THE CARTRIDGE.

SPECIFICATIONS

- Lightweight: 0.8 kg / 2.1 lbs
- Cartridge Holder Length: 243 mm / 9.6 in
- Maximum Thrust: 5 kN (stroke 3.5 mm)
- Handle Material: Reinforced Nylon
- Cartridge Holder Material: Reinforced Nylon
- Cartridge Capacity: 330 mL (11.6 oz)
- Cartridge Ratio: 10:1
- Mechanical Advantage Ratio: 26:1
- Viscosity: Medium
- Standard Color: Black
- Customized versions on demand

DIMENSIONS

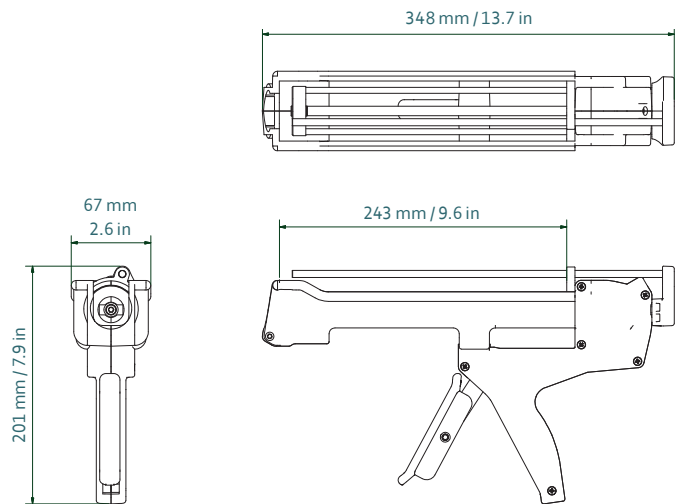

Part number	Article number	Packaging
DM2K 330-10-r26-101	151770	10 per Box

MATCHING MIXPAC™ COAXIAL CARTRIDGES

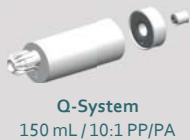

COMPATIBLE COAXIAL CARTRIDGES

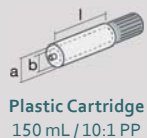

	mm	inch
l	117.0	4.6
a	∅ 50.0	∅ 1.9
b	∅ 14.3	∅ 0.5

	mm	inch
l	218.0	8.58
a	∅ 50.0	∅ 1.97
b	∅ 14.2	∅ 0.5

CONVERSION KITS

MATCHING ACCESSORIES

H285 SM / H285 S

380 ML CARTRIDGE DISPENSER

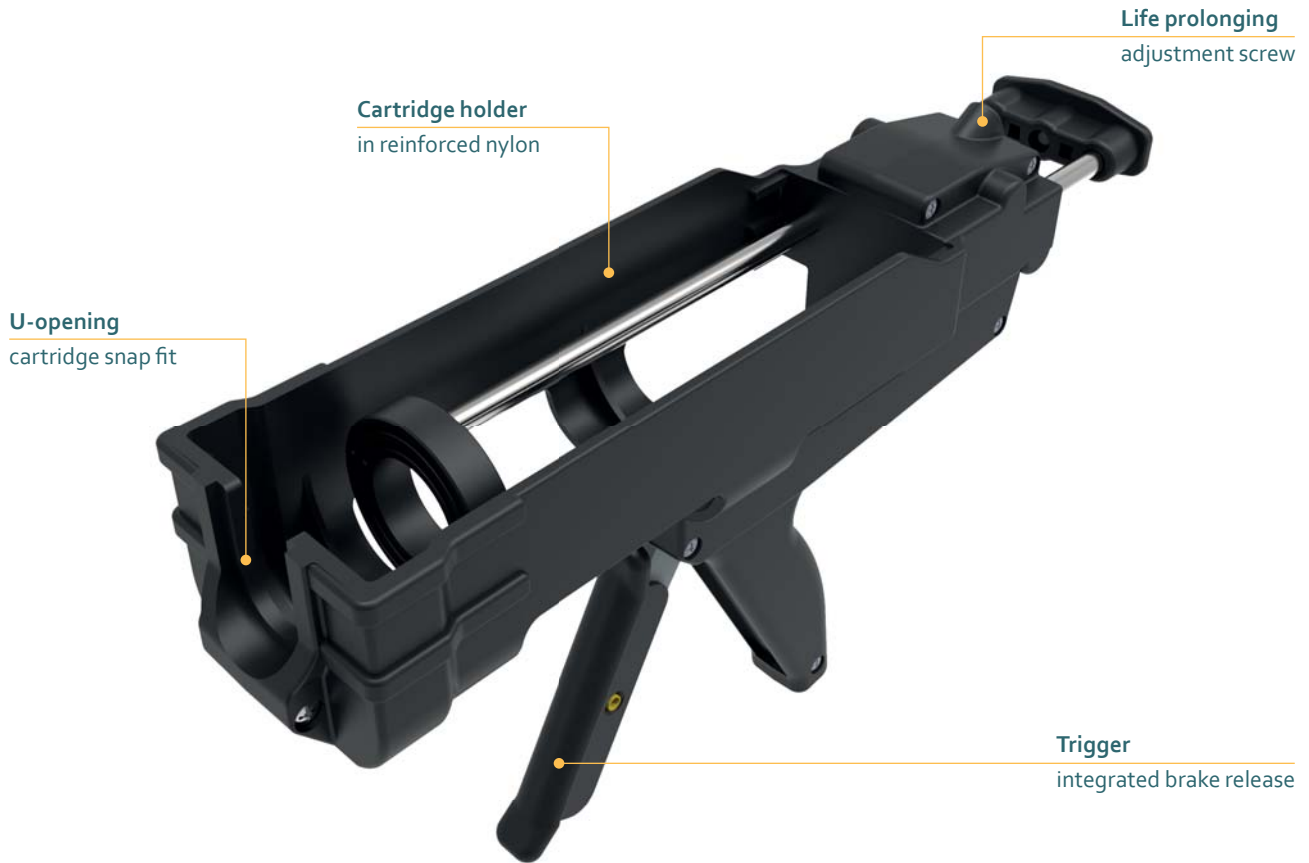

Model shown: H285 sM 380 mL

FEATURES

- Anti-drip and trigger integrated brake release
- Life prolonging adjustment screw
- Reinforced nylon barrel housing
- High gearing ratio
- U-opening with cartridge snap fit
- Customization possible

BENEFITS

- Fast, reliable and clean application
- No loss of performance – anti-wear
- Long life technology
- Easy handling for precise working
- Easy insertion and removal of cartridges
- Customer labelling

APPLICATIONS



PRODUCT BY RANGE



THE H285 2-COMPONENT MANUAL DISPENSER IS DESIGNED FOR USE WITH MEDIUM VISCOSITY SEALANTS AND ADHESIVES. THE REINFORCED U-OPENING WITH CARTRIDGE SNAP FIT OFFERS EASY HANDLING FOR PRECISE WORKING.

SPECIFICATIONS

- Lightweight: 1.0 kg / 2.2 lbs
- Cartridge Holder Length: 222 mm / 8.75 in
- Maximum Thrust: 5 kN (stroke 3.5 mm)
- Handle Material: Reinforced Nylon
- Cartridge Holder Material: Reinforced Nylon
- Cartridge Capacity: 380 mL (13.4 oz)
- Cartridge Ratios: 5:1, 10:1
- Mechanical Advantage Ratio: 26:1
- Viscosity: Medium
- Standard Color: Black
- Customized versions on demand

DIMENSIONS

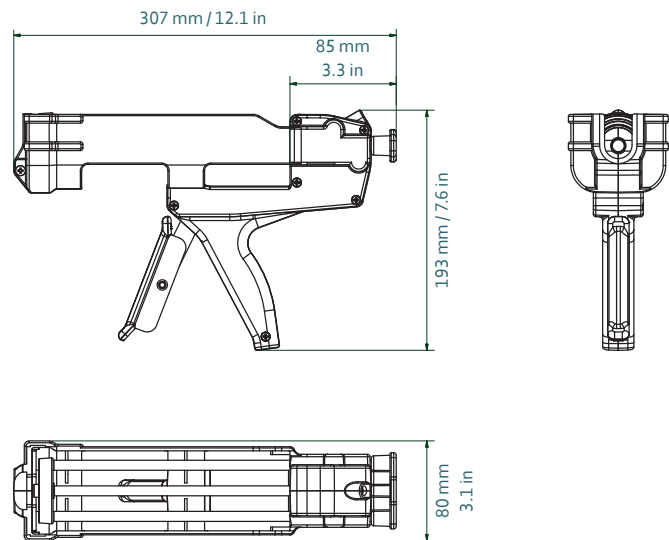

Part number	Article number	Packaging
DM2K 380-10-r26-101	151763 (H285 sM (10:1))	10 per Box
DM2K 380-05-r26-002	153461 (H285 S (5:1))	10 per Box

MATCHING MIXPAC™ COAXIAL CARTRIDGES



Q-System
380 mL / 10:1 PA

COMPATIBLE COAXIAL CARTRIDGES

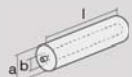

Plastic Cartridge
380 mL / 5:1 PP/PA

10:1	mm	inch
l	183.0	7.2
a	Ø 63.0	Ø 2.5
b	Ø 25.2	Ø 0.99

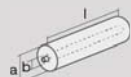

Plastic Cartridge
380 mL / 10:1 PP/PA

10:1	mm	inch
l	183.0	7.2
a	Ø 63.0	Ø 2.5
b	Ø 18.0	Ø 0.71

CONVERSION KITS

MATCHING ACCESSORIES

H260 / H260 M

345/350 ML CARTRIDGE DISPENSER



Model shown: H260 350 mL

FEATURES

- Anti-drip and trigger integrated brake release
- Life prolonging adjustment screw
- Reinforced nylon barrel housing
- High gearing ratio
- U-opening with cartridge snap fit
- Customization possible

BENEFITS

- Fast, reliable and clean application
- No loss of performance – anti-wear
- Long life technology
- Easy handling for precise working
- Easy insertion and removal of cartridges
- Customer labelling

APPLICATIONS



PRODUCT BY RANGE



THE H260 / 260 M 2-COMPONENT MANUAL DISPENSERS REINFORCED U-OPENING BARREL HOUSING WITH CARTRIDGE SNAP FIT AND HIGH GEARING RATIO OFFERS EASY HANDLING FOR PRECISE WORKING.

SPECIFICATIONS

- Lightweight: 0.9 kg / 1.9 lbs
- Cartridge Holder Length: 264 mm / 10.4 in
- Maximum Thrust: 5 kN (stroke 3.5 mm)
- Handle Material: Reinforced Nylon
- Cartridge Holder Material: Reinforced Nylon
- Cartridge Capacity: 345 mL (11.7 oz), 350 mL (12.3 oz)
- Cartridge Ratio: 10:1
- Mechanical Advantage Ratio: 26:1
- Viscosity: Medium
- Standard Color: Black
- Customized versions on demand

DIMENSIONS

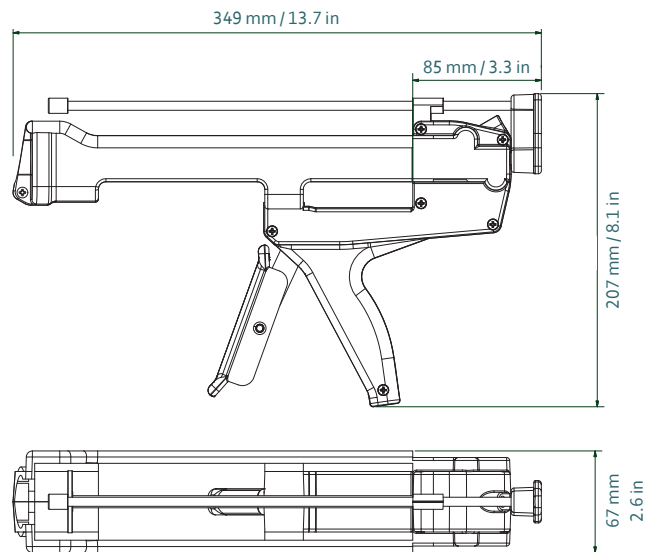

Part number	Article number	Packaging
DM2K 345-10-r26-201	151751 (H260 345 mL)	1 per Box, 10 per master carton
DM2K 350-10-r26-101	153353 (H260 M 350 mL)	1 per box, 10 per master carton

MATCHING MIXPAC™ SIDE-BY-SIDE CARTRIDGES



J-System
350 mL / 10:1 PP/PA

COMPATIBLE SIDE-BY-SIDE CARTRIDGES

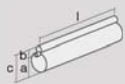

Plastic Cartridge
345 mL / 10:1 PP/PA

10:1	mm	inch
l	215.0	8.48
a	Ø 50.0	Ø 1.97
b	Ø 18.0	Ø 0.71
c	69.0	2.72

CONVERSION KITS

MATCHING ACCESSORIES

H244 S

385 ML CARTRIDGE DISPENSER

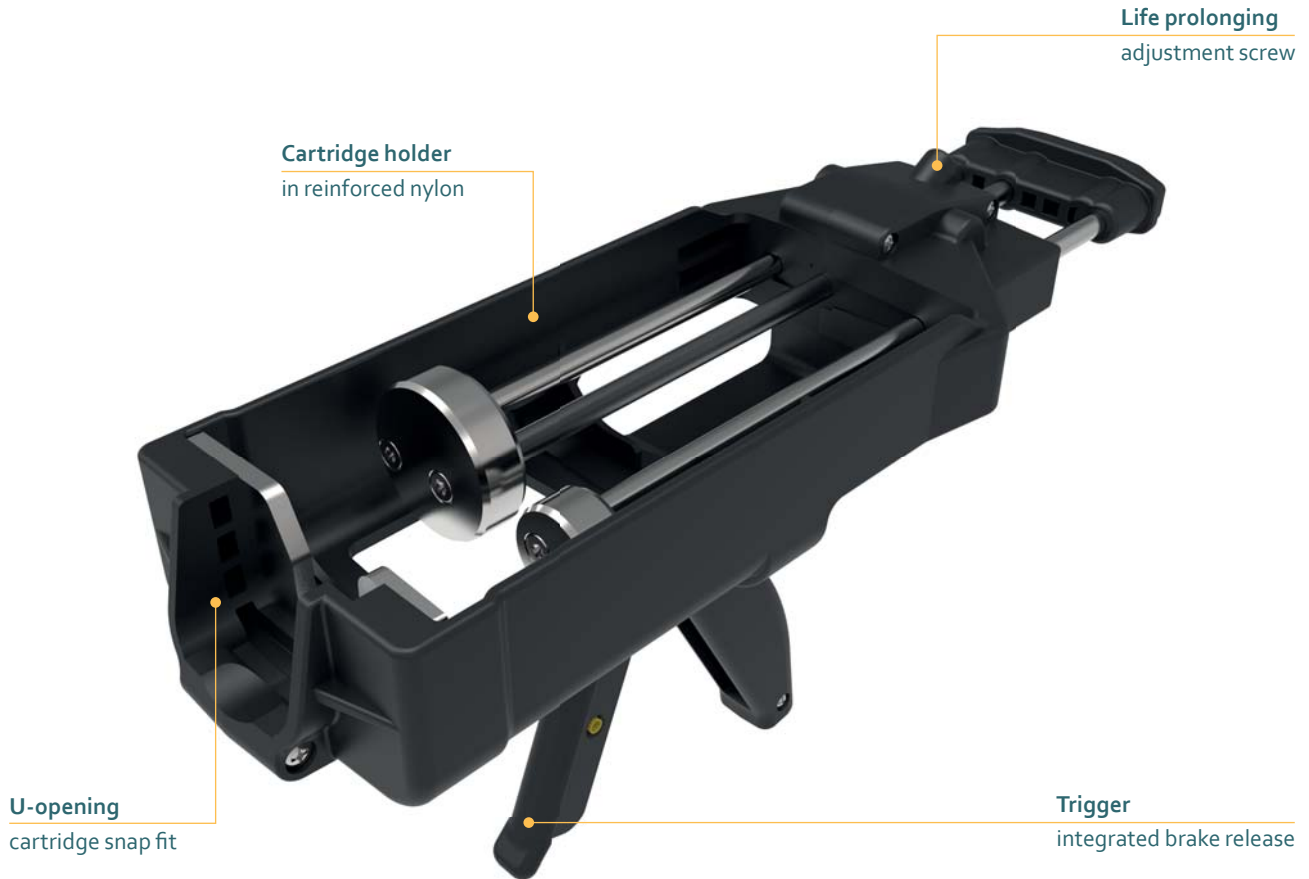

Model shown: H244 s 385 mL

FEATURES

- Anti-drip and trigger integrated brake release
- Life prolonging adjustment screw
- Reinforced nylon barrel housing
- High gearing ratio
- U-opening with cartridge snap fit
- Customization possible

BENEFITS

- Fast, reliable and clean application
- No loss of performance – anti-wear
- Long life technology
- Easy handling for precise working
- Easy insertion and removal of cartridges
- Customer labelling

APPLICATIONS



Chemical
Anchoring

PRODUCT BY RANGE



H244 s

THE H244 S 2-COMPONENT MANUAL DISPENSER'S ANTI-DRIP AND TRIGGER INTEGRATED BRAKE RELEASE GIVE A RELIABLE, FAST APPLICATION, WHILE THE LIFE PROLONGING ADJUSTMENT SCREW OFFERS LIFE-LONG TECHNOLOGY.

SPECIFICATIONS

- Lightweight: 1.22 kg / 2.6 lbs
- Cartridge Holder Length: 187 mm / 7.4 in
- Maximum Thrust: 5 kN (stroke 3.5 mm)
- Handle Material: Reinforced Nylon
- Cartridge Holder Material: Reinforced Nylon
- Cartridge Capacity: 385 mL (13.6 oz)
- Cartridge Ratio: 3:1
- Mechanical Advantage Ratio: 26:1
- Viscosity: High
- Standard Color: Black
- Customized versions on demand

DIMENSIONS

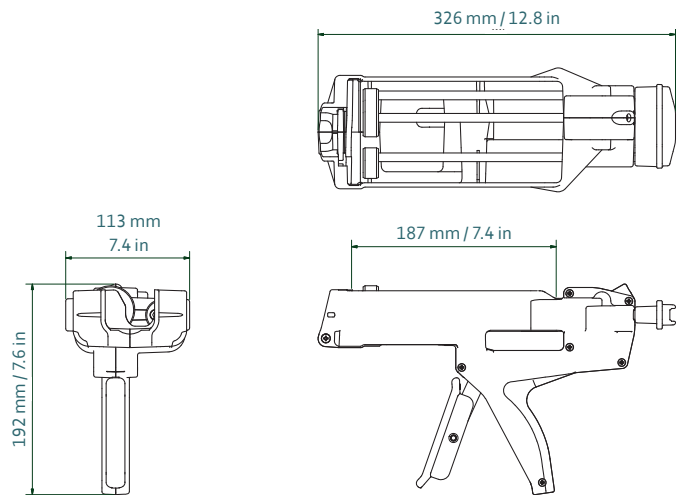

Part number	Article number	Packaging
DM2K 385-03-r26-001	153509	1 per box, 10 per master carton

MATCHING MIXPAC™ SIDE-BY-SIDE CARTRIDGES



J-System
365 mL / 3:1 PP

COMPATIBLE SIDE-BY-SIDE CARTRIDGES

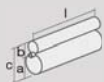

Plastic Cartridge
385 mL / 3:1 PP/PA

3:1	mm	inch
l	171.0	6.73
a	Ø 54.4	Ø 2.14
b	Ø 32.6	Ø 1.28
c	90.0	3.54

CONVERSION KITS

MATCHING ACCESSORIES

H288 / H288 M / H288 N

600/620 ML CARTRIDGE DISPENSER



Model shown: H288 380 mL

FEATURES

- Anti-drip and trigger integrated brake release
- Life prolonging adjustment screw
- Reinforced nylon barrel housing
- High gearing ratio
- U-opening with cartridge snap fit
- Customization possible

BENEFITS

- Fast, reliable and clean application
- No loss of performance – anti-wear
- Long life technology
- Easy handling for precise working
- Easy insertion and removal of cartridges
- Customer labelling

APPLICATIONS



PRODUCT BY RANGE



THE H288 / H288 M / H288 N 2-COMPONENT MANUAL DISPENSER IS DESIGNED FOR USE WITH MEDIUM VISCOSITY SEALANTS AND ADHESIVES WHILE THE ANTI-WEAR LIFE PROLONGING ADJUSTMENT SCREW OFFERS LIFE-LONG TECHNOLOGY.

SPECIFICATIONS

- Lightweight: 1.2 kg / 2.6 lbs
- Cartridge Holder Length: 231 mm / 9.1 in
- Maximum Thrust: 5 kN (stroke 3.5 mm)
- Handle Material: Reinforced Nylon
- Cartridge Holder Material: Reinforced Nylon
- Cartridge Capacity: 600 mL (21.1 oz), 620 mL (21.8 oz)
- Cartridge Ratio: 1:1
- Mechanical Advantage Ratio: 26:1
- Viscosity: Medium
- Standard Color: Black
- Customized versions on demand

DIMENSIONS

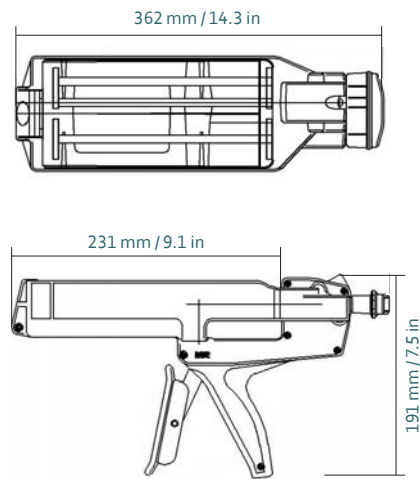

Part number	Article number	Packaging
DM2K 620-01-r26-101	151765 (H288 (620 mL))	1 per box, 10 per master carton
DM2K 600-01-r26-401	151766 (H288 M J-System, ecopaCC)	1 per box, 10 per master carton
DM2K 600-01-r26-201	152494 (H288 N (600 mL))	1 per box, 10 per master carton

MATCHING MIXPAC™ CARTRIDGES



J-System
600 mL / 1:1 PP



ecopaCC Cartridge
600 mL / 1:1

COMPATIBLE SIDE-BY-SIDE CARTRIDGE

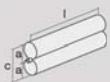

Plastic Cartridge
600 mL / 1:1 PP

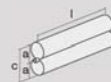

Plastic Cartridge
620 mL (2 x 310 mL) / 1:1 PP

1:1	mm	inch
l	215.0	8.46
a	∅ 49.3	∅ 1.94
c	98.5	3.88

1:1	mm	inch
l	217.0	8.54
a	∅ 48.0	∅ 1.89
c	95.5	3.76

CONVERSION KITS

MATCHING ACCESSORIES

H293 / H293 PM

450/600 ML CARTRIDGE DISPENSER



Model shown: H293 600 mL

FEATURES

- Anti-drip and trigger integrated brake release
- Life prolonging adjustment screw
- Reinforced nylon barrel housing
- High gearing ratio
- U-opening with cartridge snap fit
- Customization possible

BENEFITS

- Fast, reliable and clean application
- No loss of performance – anti-wear
- Long life technology
- Easy handling for precise working
- Easy insertion and removal of cartridges
- Customer labelling

APPLICATIONS



Chemical
Anchoring

PRODUCT BY RANGE



H293

H293 PM

THE H293 / 293 PM 2-COMPONENT MANUAL DISPENSERS REINFORCED U-OPENING BARREL HOUSING WITH CARTRIDGE SNAP FIT AND HIGH GEARING RATIO OFFERS EASY HANDLING FOR PRECISE WORKING.

SPECIFICATIONS

- Lightweight: 1.2 kg / 2.6 lbs
- Cartridge Holder Length: 231 mm / 9.1 in
- Maximum Thrust: 5 kN (stroke 3.5 mm)
- Handle Material: Reinforced Nylon
- Cartridge Holder Material: Reinforced Nylon
- Cartridge Capacity: 450 mL (15.8 oz), 600 mL (21.1 oz)
- Cartridge Ratios: 1:1, 2:1
- Mechanical Advantage Ratio: 26:1
- Viscosity: High
- Standard Color: Black
- Customized versions on demand

DIMENSIONS

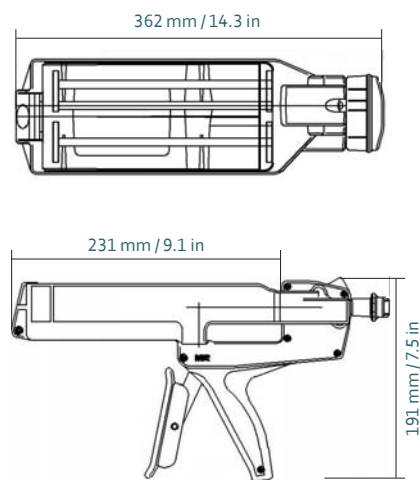

Part number	Article number	Packaging
DM2K 600-01-r26-101	151767 (H293 (600 mL))	1 per box, 10 per master carton
DM2K 450-02-r26-001	151768 (H293 PM (J-System 450 mL))	1 per box, 10 per master carton

MATCHING MIXPAC™ CARTRIDGES



J-System
450 mL / 2:1 PP/PA

COMPATIBLE SIDE-BY-SIDE CARTRIDGES

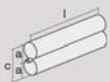

Plastic Cartridge
600 mL / 1:1 PP

1:1	mm	inch
l	217.0	8.54
a	Ø 48.0	Ø 1.89
c	95.5	3.76

CONVERSION KITS

MATCHING ACCESSORIES

H239

900 ML CARTRIDGE DISPENSER



Model shown: H239 900 mL

FEATURES

- Anti-drip and trigger integrated brake release
- Life prolonging adjustment screw
- Reinforced nylon frame and handle
- U-opening with cartridge snap fit
- Customization possible

BENEFITS

- Fast, reliable and clean application
- No loss of performance – anti-wear
- Long life technology
- Easy insertion and removal of cartridges
- Customer labelling

APPLICATIONS



Chemical
Anchoring

PRODUCT BY RANGE



H239

THE H239 2-COMPONENT MANUAL DISPENSER IS FOR USE WITH HIGH VISCOSITY SEALANTS AND ADHESIVES, WHILE ANTI-DRIP AND TRIGGER INTEGRATED BRAKE RELEASE GIVE A RELIABLE, FAST APPLICATION.

SPECIFICATIONS

- Lightweight: 2.08 kg / 4.5 lbs
- Cartridge Holder Length: 235 mm / 9.25 in
- Maximum Thrust: 5 kN (stroke 3.5 mm)
- Handle Material: Reinforced Nylon
- Cartridge Holder Material: Steel
- Cartridge Capacity: 900 mL (31.7 oz)
- Cartridge Ratio: 2:1
- Mechanical Advantage Ratio: 26:1
- Viscosity: High
- Standard Color: Black/Red
- Customized versions on demand

DIMENSIONS

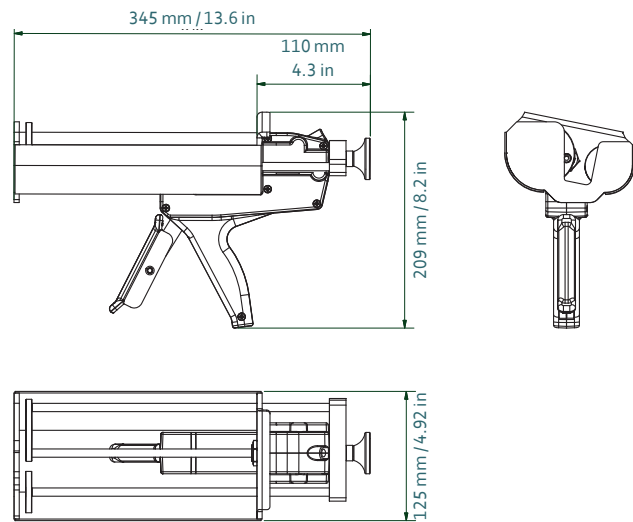

Part number	Article number	Packaging
DM2K 1200-02-r26-001	151748	1 per box, 4 per master carton

MATCHING MIXPAC™ CARTRIDGES

COMPATIBLE SIDE-BY-SIDE CARTRIDGES



Plastic Cartridge
900 mL / 2:1 PP/PA

2:1	mm	inch
l	255.0	8.86
a	Ø 69.0	Ø 2.72
b	Ø 50.0	Ø 1.97
c	119.0	4.69

CONVERSION KITS

MATCHING ACCESSORIES

B948 M

200 ML CARTRIDGE DISPENSER

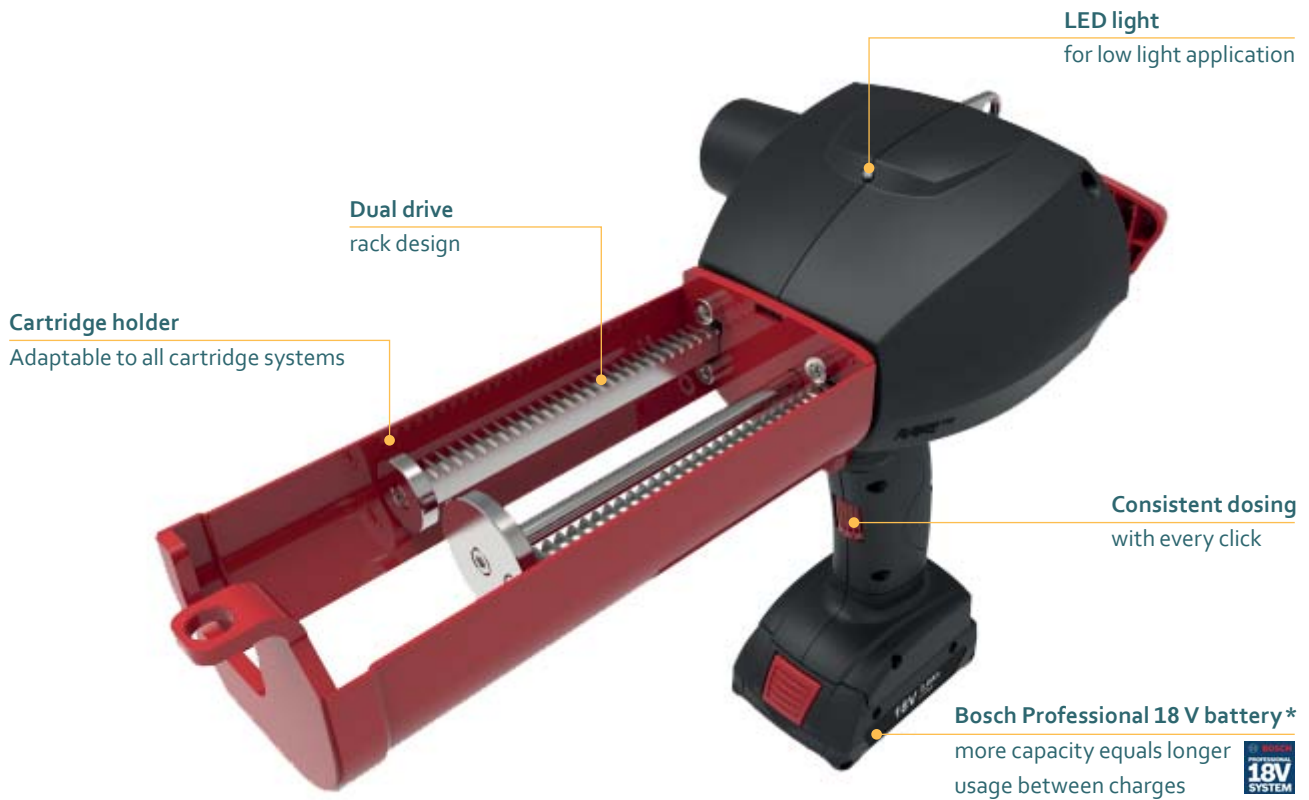

Model shown: B948 M 200 mL

FEATURES

- Unique memory function
- Dual drive rack design
- Anti-drip function
- 18 V Li-ion high performance battery
- U-opening with cartridge snap fit
- Customization possible

BENEFITS

- Consistent dosing with every click
- Reproduces quality of each adhesive
- Clean and efficient working
- Charge time: 65 min (100%)
- For easy insertion and removal of cartridges
- Customer labelling

APPLICATIONS

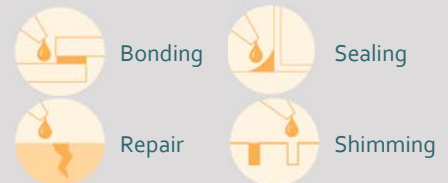

PRODUCT BY RANGE



THE B948 M 2-COMPONENT BATTERY DISPENSER DUAL DRIVE RACK AND UNIQUE MEMORY FUNCTION REPRODUCES CONSISTENT DOSING EVERY TIME, WHILE THE BOSCH PROFESSIONAL 18 V RE-CHARGEABLE BATTERY OFFERS LONGER USAGE BETWEEN CHARGES.

SPECIFICATIONS

- Weight: 3.5 kg / 7.7 lbs
- Cartridge Holder Length: 200 mm / 7.9 in
- Maximum Thrust: 4 kN (5 mm/s)
- Voltage: 18 V
- Battery Capacity: 2.0 Ah
- Battery Charge Time: 65 min (100%)
- Battery Type: Li-ion
- Handle Material: Reinforced Nylon
- Cartridge Holder Material: Steel
- Cartridge Capacity: 200 mL (7 oz)
- Cartridge Ratio: 1:1
- Viscosity: High
- Standard Color: Black/Red
- Customized versions on demand

DIMENSIONS

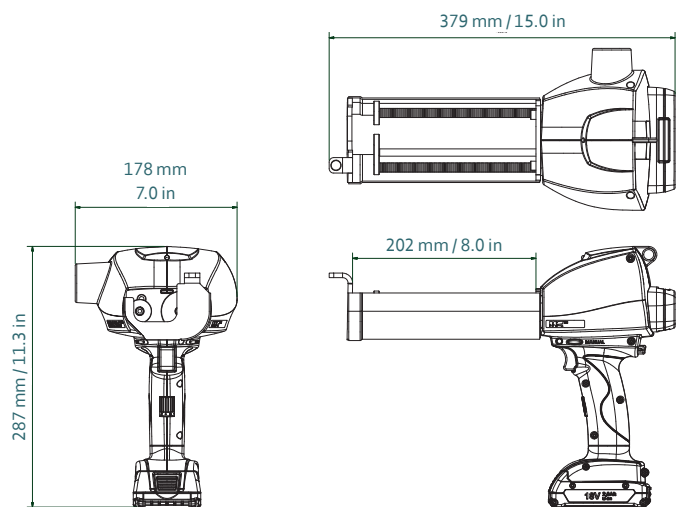

Part number	Article number	Packaging
DB2K 200-01-500-001	153190	1 per Box

MATCHING MIXPAC™ CARTRIDGES



C-System/F-System
200 mL / 1:1 PP/PA

COMPATIBLE SIDE-BY-SIDE CARTRIDGES

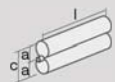

Plastic Cartridge
200 mL / 1:1 PP

1:1	mm	inch
l	148.0	5.83
a	Ø 37.0	Ø 1.46
c	79.0	3.11

CONVERSION KITS

–

MATCHING ACCESSORIES

Batteries and chargers on pages 90.

B983 M

400 ML CARTRIDGE DISPENSER

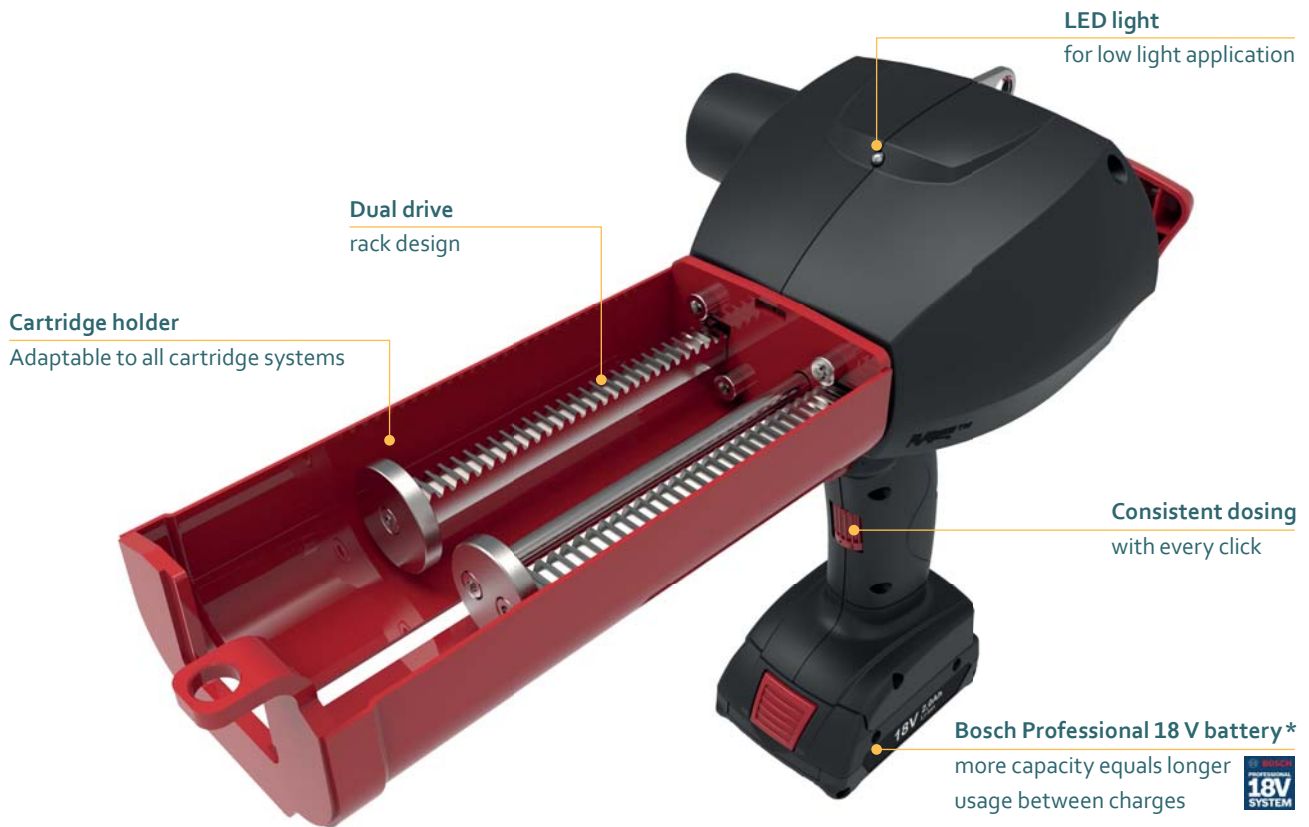

Model shown: B983 M 400 mL

FEATURES

- Unique memory function
- Dual drive rack design
- Anti-drip function
- 18 V Li-ion high performance battery
- U-opening with cartridge snap fit
- Customization possible

BENEFITS

- Consistent dosing with every click
- Reproduces quality of each adhesive
- Clean and efficient working
- Charge time: 65 min (100%)
- For easy insertion and removal of cartridges
- Customer labelling

APPLICATIONS



PRODUCT BY RANGE



THE B983 M 2-COMPONENT BATTERY DISPENSERS U-OPENING STEEL FRAME ALLOWS FOR EASY INSERTION AND REMOVAL OF CARTRIDGES, WHILE THE BOSCH PROFESSIONAL 18 V RECHARGEABLE BATTERY OFFERS LONGER USAGE BETWEEN CHARGES.

SPECIFICATIONS

- Weight: 3.5 kg / 7.7 lbs
- Cartridge Holder Length: 200 mm / 7.9 in
- Maximum Thrust: 5 kN (5 mm/s)
- Voltage: 18 V
- Battery Capacity: 2.0 Ah
- Battery Charge Time: 65 min (100%)
- Battery Type: Li-ion
- Handle Material: Reinforced Nylon
- Cartridge Holder Material: Steel
- Cartridge Capacity: 400 mL (14 oz)
- Cartridge Ratio: 1:1
- Viscosity: High
- Standard Color: Black/Red
- Customized versions on demand

DIMENSIONS

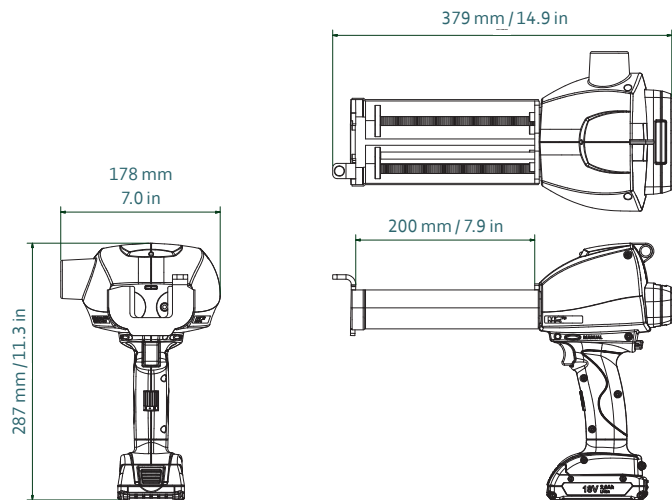

Part number	Article number	Packaging
DB2K 400-01-500-001	152603	1 per Box
DB2K 400-01-500-1US	152604 (US)	1 per Box

MATCHING MIXPAC™ SIDE-BY-SIDE CARTRIDGES

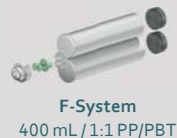
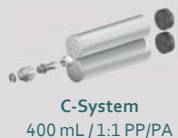

COMPATIBLE CARTRIDGES

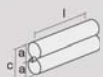

Plastic Cartridge
400 mL / 1:1 PP/PBT

1:1	mm	inch
l	185.0	7.28
a	Ø 45.0	Ø 1.77
c	93.0	3.66

CONVERSION KITS

–

MATCHING ACCESSORIES

Batteries and chargers on pages 90.

B983 M-2:1

400 ML CARTRIDGE DISPENSER

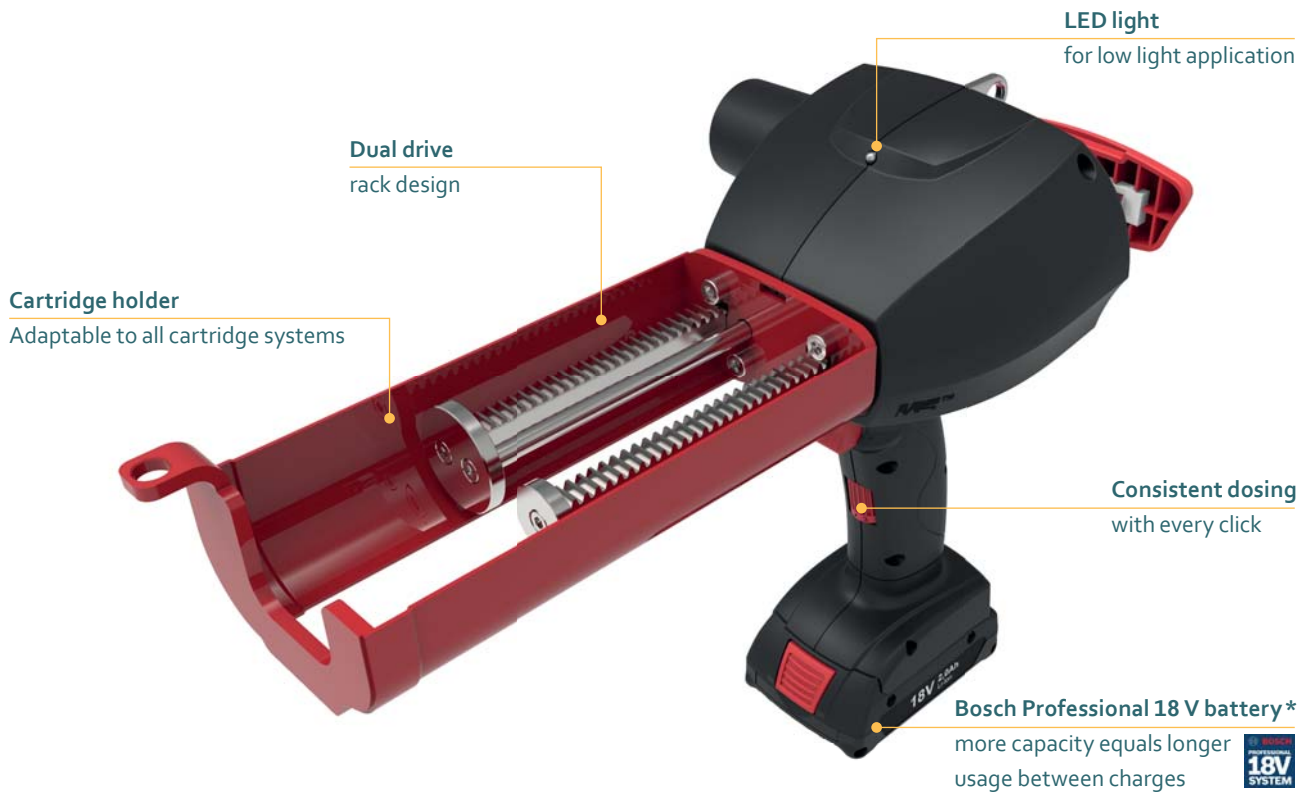

Model shown: B983 M-2:1 400 mL

FEATURES

- Unique memory function
- Dual drive rack design
- Anti-drip function
- 18 V Li-ion high performance battery
- U-opening with cartridge snap fit
- Customization possible

BENEFITS

- Consistent dosing with every click
- Reproduces quality of each adhesive
- Clean and efficient working
- Charge time: 65 min (100%)
- For easy insertion and removal of cartridges
- Customer labelling

APPLICATIONS

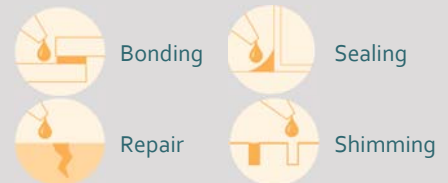

PRODUCT BY RANGE



THE B983 M-2:1 2-COMPONENT BATTERY DISPENSER IS DESIGNED FOR USE WITH HIGH VISCOSITY SEALANTS AND ADHESIVES, WHILE THE DUAL DRIVE RACK AND UNIQUE MEMORY FUNCTION REPRODUCES CONSISTENT DOSING EVERY TIME.

SPECIFICATIONS

- Weight: 3.5 kg / 7.7 lbs
- Cartridge Holder Length: 202 mm / 7.95 in
- Maximum Thrust: 5 kN (5 mm/s)
- Voltage: 18 V
- Battery Capacity: 2.0 Ah
- Battery Charge Time: 65 min (100%)
- Battery Type: Li-ion
- Handle Material: Reinforced Nylon
- Cartridge Holder Material: Steel
- Cartridge Capacity: 400 mL (14 oz)
- Cartridge Ratio: 2:1
- Viscosity: High
- Standard Color: Black/Red
- Customized versions on demand

DIMENSIONS

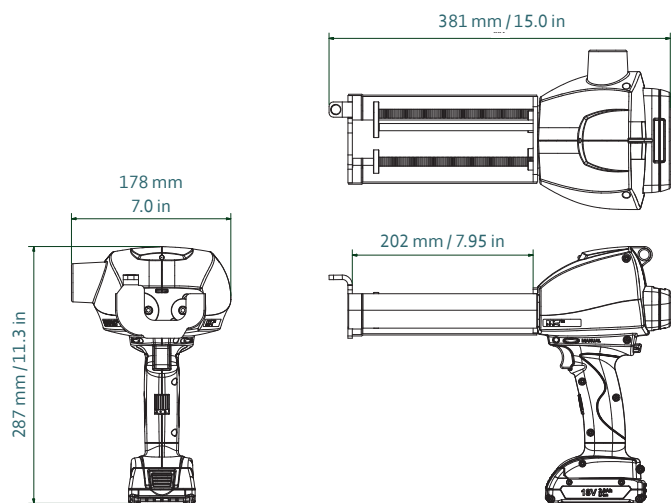

Part number	Article number	Packaging
DB2K 400-02-500-001	152605	1 per Box
DB2K 400-02-500-1US	152606 (US)	1 per Box

MATCHING MIXPAC™ SIDE-BY-SIDE CARTRIDGES

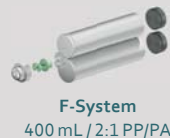
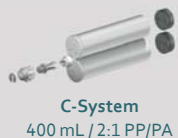

COMPATIBLE CARTRIDGES

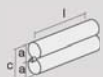

Plastic Cartridge
400 mL / 2:1 PP/PBT

2:1	mm	inch
l	185.0	7.28
a	Ø 47.0	Ø 1.85
b	Ø 33.0	Ø 1.3
c	96.0	3.78

CONVERSION KITS

—

MATCHING ACCESSORIES

Batteries and chargers on pages 90.

B938 M

400 ML CARTRIDGE DISPENSER

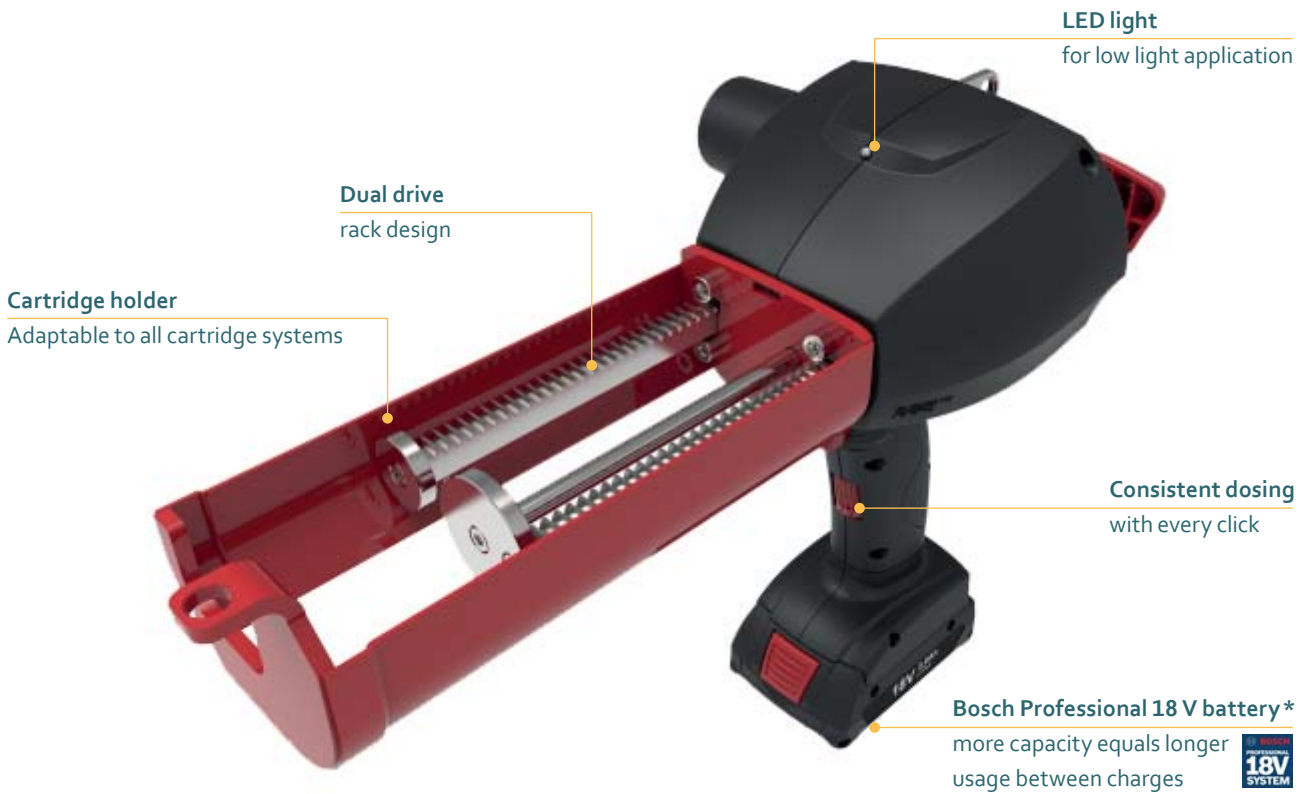

Model shown: B938 M 400 mL

FEATURES

- Unique memory function
- Dual drive rack design
- Anti-drip function
- 18 V Li-ion high performance battery
- U-opening with cartridge snap fit
- Customization possible

BENEFITS

- Consistent dosing with every click
- Reproduces quality of each adhesive
- Clean and efficient working
- Charge time: 65 min (100%)
- For easy insertion and removal of cartridges
- Customer labelling

APPLICATIONS

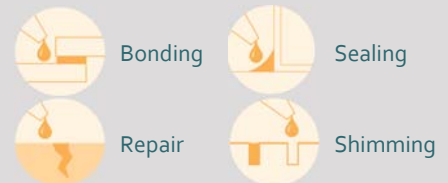

PRODUCT BY RANGE



THE B938 M 2-COMPONENT BATTERY DISPENSER IS DESIGNED FOR USE WITH HIGH VISCOSITY SEALANTS AND ADHESIVES, WHILE THE DUAL DRIVE RACK AND UNIQUE MEMORY FUNCTION REPRODUCES CONSISTENT DOSING EVERY TIME.

SPECIFICATIONS

- Weight: 3.5 kg / 7.7 lbs
- Cartridge Holder Length: 202 mm / 7.95 in
- Maximum Thrust: 5 kN (5 mm/s)
- Voltage: 18 V
- Battery Capacity: 2.0 Ah
- Battery Charge Time: 65 min (100%)
- Battery Type: Li-ion
- Handle Material: Reinforced Nylon
- Cartridge Holder Material: Steel
- Cartridge Capacity: 400 mL (14 oz)
- Cartridge Ratio: 4:1
- Viscosity: High
- Standard Color: Black/Red
- Customized versions on demand

DIMENSIONS

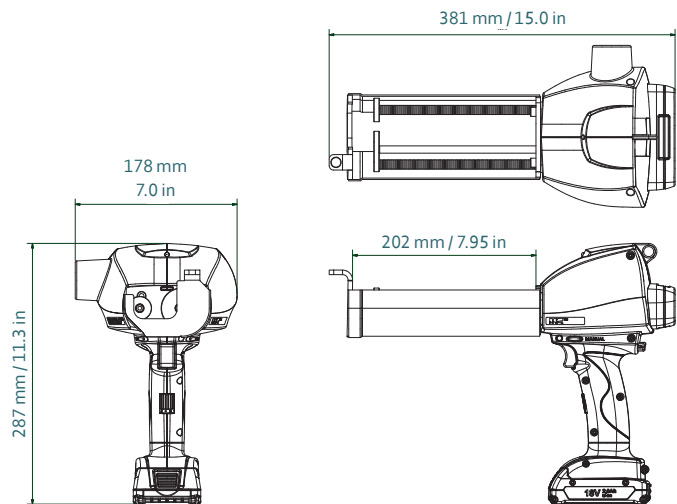

Part number	Article number	Packaging
DB2K 400-04-500-001	152607	1 per Box
DB2K 400-04-500-1US	152608 (US)	1 per Box

MATCHING MIXPAC™ SIDE-BY-SIDE CARTRIDGES



C-System
400 mL / 4:1 PP



F-System
400 mL / 4:1 PP/PBT

COMPATIBLE CARTRIDGES

—

CONVERSION KITS

—

MATCHING ACCESSORIES

Batteries and chargers on pages 90.

B978 M

400 ML CARTRIDGE DISPENSER

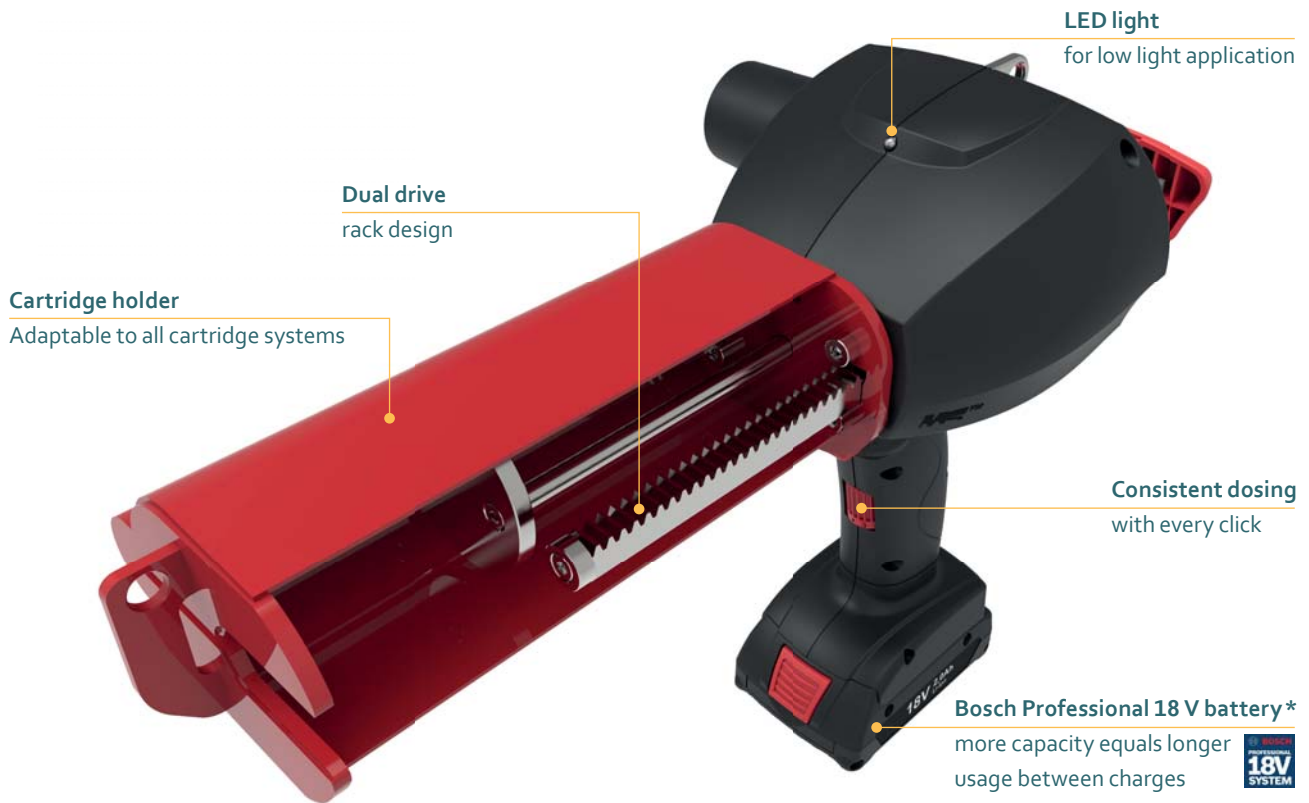

Model shown: B978 M 400 mL

FEATURES

- Unique memory function
- Dual drive rack design
- Anti-drip function
- 18 V Li-ion high performance battery
- U-opening with cartridge snap fit
- Customization possible

BENEFITS

- Consistent dosing with every click
- Reproduces quality of each adhesive
- Clean and efficient working
- Charge time: 65 min (100%)
- For easy insertion and removal of cartridges
- Customer labelling

APPLICATIONS

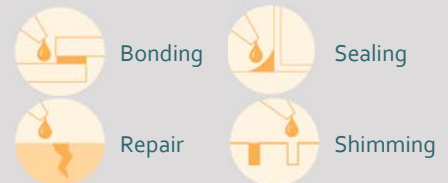

PRODUCT BY RANGE



THE B978 M 2-COMPONENT BATTERY DISPENSER DUAL DRIVE RACK AND UNIQUE MEMORY FUNCTION REPRODUCES CONSISTENT DOSING EVERY TIME, WHILE THE THE BOSCH PROFESSIONAL 18 V RE-CHARGEABLE BATTERY OFFERS LONGER USAGE BETWEEN CHARGES.

SPECIFICATIONS

- Weight: 3.5 kg / 7.7 lbs
- Cartridge Holder Length: 199 mm / 7.8 in
- Maximum Thrust: 5 kN (5 mm/s)
- Voltage: 18 V
- Battery Capacity: 2.0 Ah
- Battery Charge Time: 65 min (100%)
- Battery Type: Li-ion
- Handle Material: Reinforced Nylon
- Cartridge Holder Material: Steel
- Cartridge Capacity: 400 mL (14 oz)
- Cartridge Ratio: 10:1
- Viscosity: High
- Standard Color: Black/Red
- Customized versions on demand

DIMENSIONS

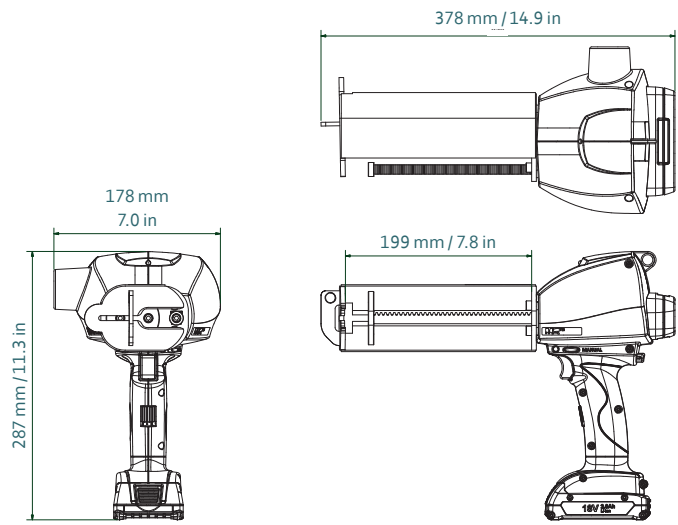

Part number	Article number	Packaging
DB2K 400-10-500-001	152609	1 per Box
DB2K 400-10-500-1US	152610 (US)	1 per Box

MATCHING MIXPAC™ SIDE-BY-SIDE CARTRIDGES

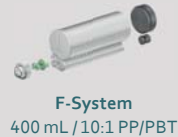
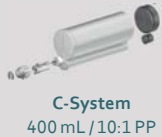

COMPATIBLE CARTRIDGES



10:1	mm	inch
l	185.0	7.28
a	∅ 65.0	∅ 2.56
b	∅ 19.5	∅ 0.77
c	94.0	3.7

CONVERSION KITS

—

MATCHING ACCESSORIES

Batteries and chargers on pages 90.

B944 K

365/385/585 ML CARTRIDGE DISPENSER

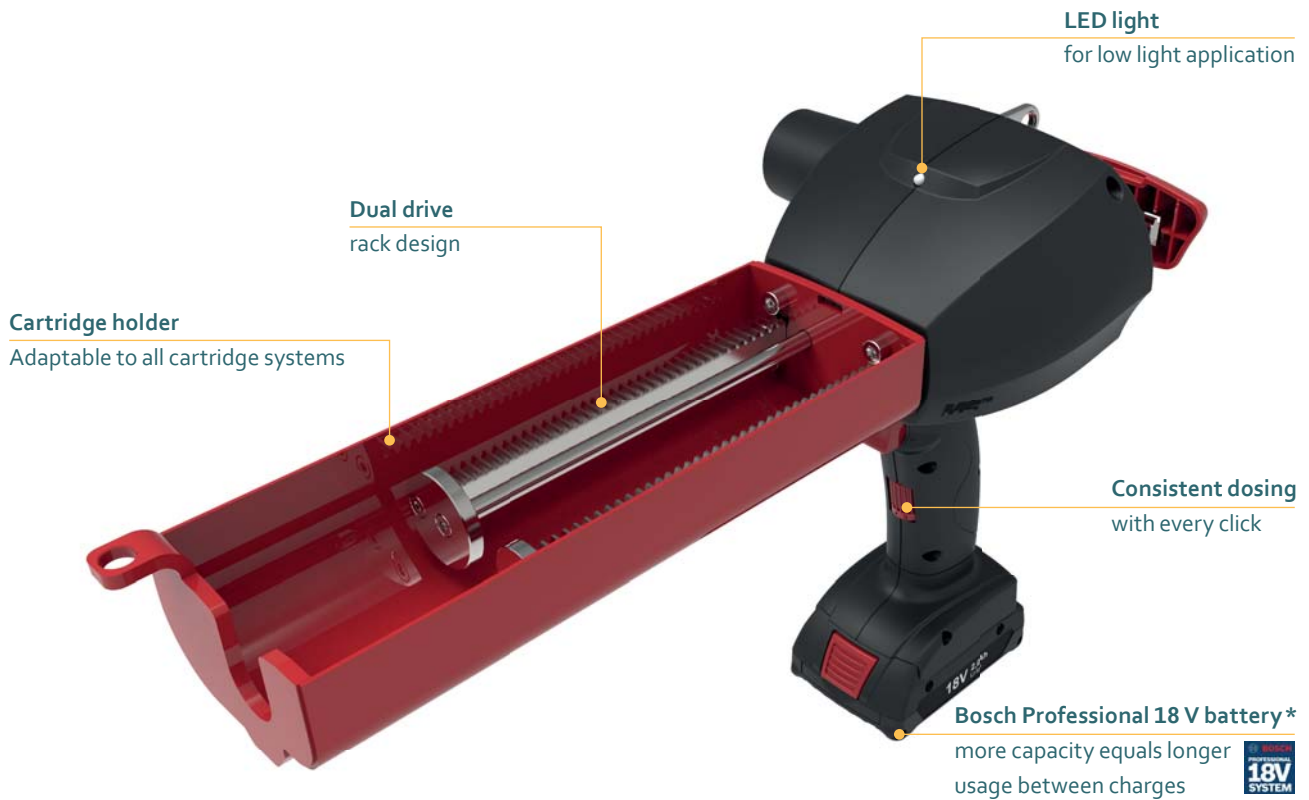

Model shown: B944 K 585 mL

FEATURES

- Unique memory function
- Dual drive rack design
- Anti-drip function
- 18 V Li-ion high performance battery
- U-opening with cartridge snap fit
- Customization possible

BENEFITS

- Consistent dosing with every click
- Reproduces quality of each adhesive
- Clean and efficient working
- Charge time: 65 min (100%)
- For easy insertion and removal of cartridges
- Customer labelling

APPLICATIONS



PRODUCT BY RANGE



B944 K

THE B944 K 2-COMPONENT BATTERY DISPENSER IS DESIGNED FOR USE WITH LOW TO MEDIUM VISCOSITY SEALANTS AND ADHESIVES, WHILE THE THE BOSCH PROFESSIONAL 18 V RE-CHARGEABLE BATTERY OFFERS LONGER USAGE BETWEEN CHARGES.

SPECIFICATIONS

- Weight: 3.5 kg / 7.7 lbs
- Cartridge Holder Length: 265 mm / 10.4 in
- Maximum Thrust: 2.7 kN (5 mm/s)
- Voltage: 18 V
- Battery Capacity: 2.0 Ah
- Battery Charge Time: 65 min (100%)
- Battery Type: Li-ion
- Handle Material: Reinforced Nylon
- Cartridge Holder Material: Steel
- Cartridge Capacity: 365 mL (12.3 oz), 385 mL (13.5 oz), 585 mL (20.6 oz)
- Cartridge Ratio: 3:1
- Viscosity: Low/Medium
- Standard Color: Black/Red
- Customized versions on demand

DIMENSIONS

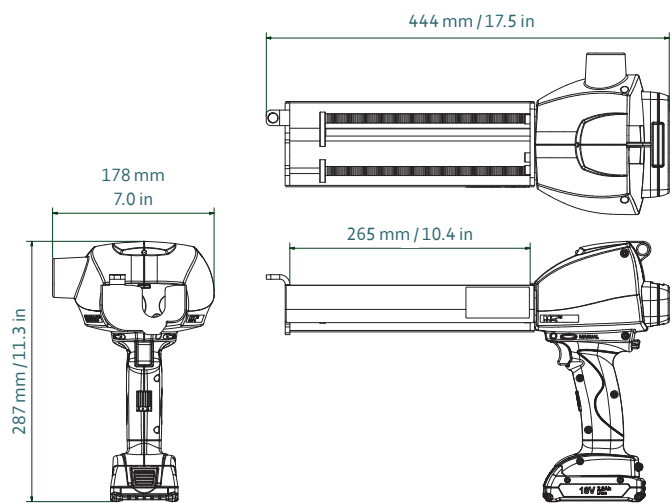

Part number	Article number	Packaging
DB2K 585-03-270-001	154476	1 per Box

MATCHING MIXPAC™ SIDE-BY-SIDE CARTRIDGES



J-System
365 mL / 3:1 PP



ecopaCC Cartridge
600 mL / 3:1

COMPATIBLE SIDE-BY-SIDE CARTRIDGES

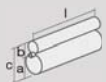

Plastic Cartridge
385 mL / 3:1 PP/PA

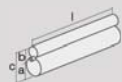

Plastic Cartridge
585 mL / 3:1 PP/PA

3:1	mm	inch
l	171.0	6.73
a	Ø 54.4	Ø 2.14
b	Ø 32.6	Ø 1.28
c	90.0	3.54

3:1	mm	inch
l	244.0	9.6
a	Ø 54.4	Ø 2.14
b	Ø 32.6	Ø 1.28
c	90.0	3.54

CONVERSION KITS

–

MATCHING ACCESSORIES

Batteries and chargers on pages 90.

B960 M

350 ML CARTRIDGE DISPENSER

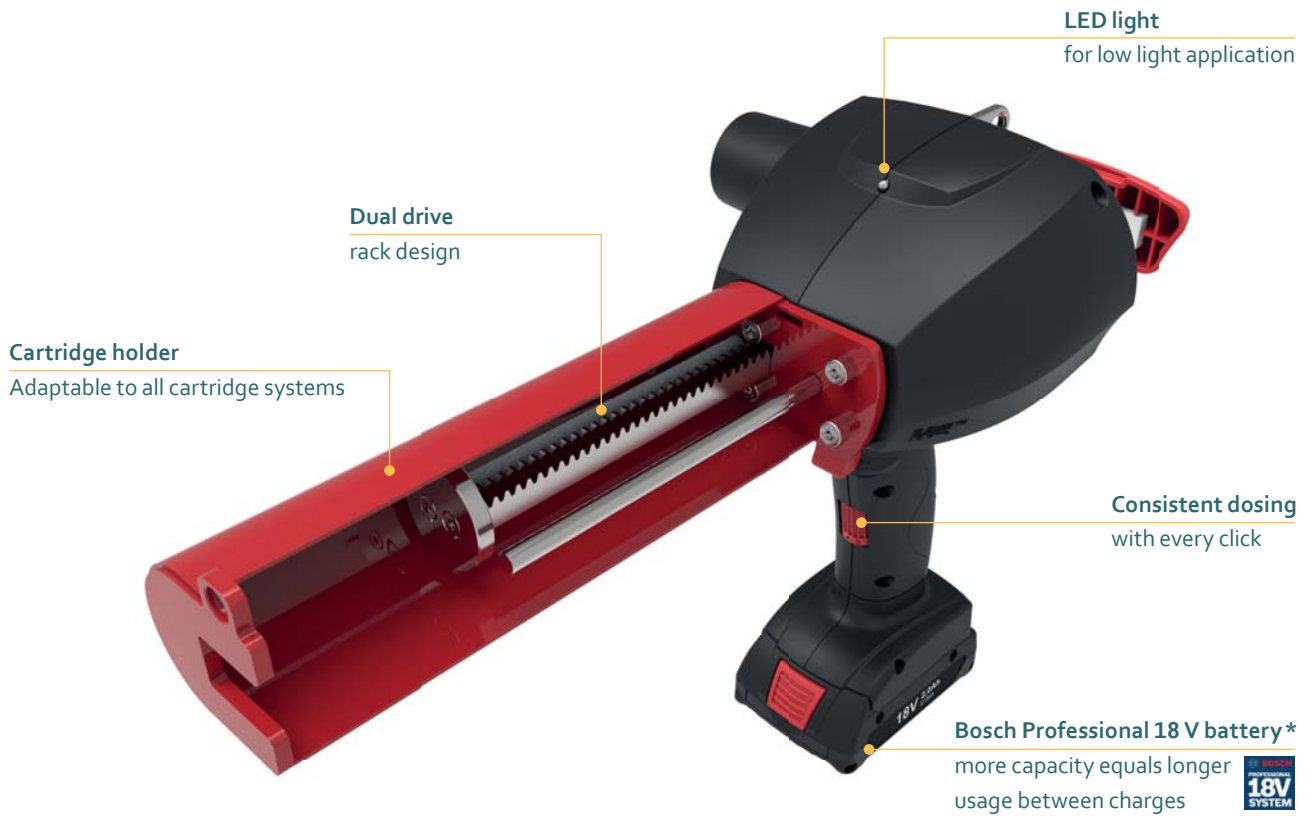

Model shown: B960 M 345 mL

FEATURES

- Unique memory function
- Dual drive rack design
- Anti-drip function
- 18 V Li-ion high performance battery
- U-opening with cartridge snap fit
- Customization possible

BENEFITS

- Consistent dosing with every click
- Reproduces quality of each adhesive
- Clean and efficient working
- Charge time: 65 min (100%)
- For easy insertion and removal of cartridges
- Customer labelling

APPLICATIONS



PRODUCT BY RANGE



B960 M

THE B960 M 2-COMPONENT BATTERY DISPENSER OFFERS CONSISTENT DOSING WITH EVERY CLICK, WHILE ACCIDENTAL MATERIAL DISCHARGE IS PREVENTED WITH THE BUILT-IN ANTI-DRIP MECHANISM.

SPECIFICATIONS

- Weight: 3.4 kg / 7.4 lbs
- Cartridge Holder Length: 232 mm / 9.1 in
- Maximum Thrust: 2.8 kN (5 mm/s)
- Voltage: 18 V
- Battery Capacity: 2.0 Ah
- Battery Charge Time: 65 min (100%)
- Battery Type: Li-ion
- Handle Material: Reinforced Nylon
- Cartridge Holder Material: Steel
- Cartridge Capacity: 350 mL (12.3 oz)
- Cartridge Ratio: 10:1
- Viscosity: Low/Medium
- Standard Color: Black/Red
- Customized versions on demand

DIMENSIONS

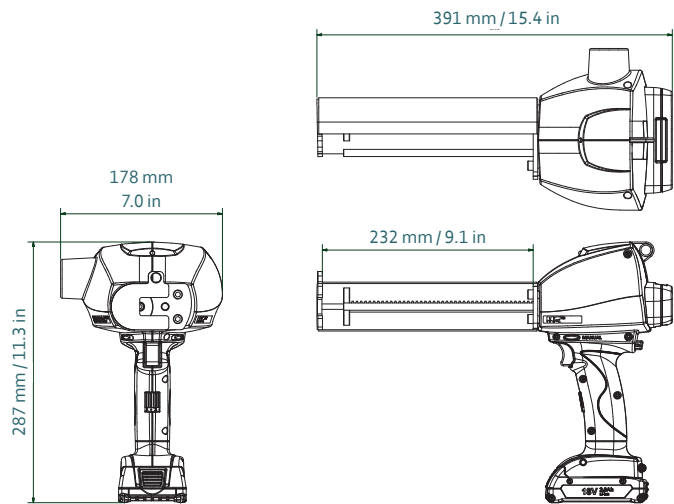

Part number	Article number	Packaging
DB2K 350-10-280-001	152602	1 per Box

MATCHING MIXPAC™ SIDE-BY-SIDE CARTRIDGES



J-System
350 mL / 10:1 PA

COMPATIBLE CARTRIDGES

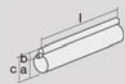

Plastic Cartridge
345 mL / 10:1 PP/PA

10:1	mm	inch
l	215.0	8.46
a	Ø 50.0	Ø 1.97
b	Ø 18.0	Ø 0.71
c	69.0	2.72

CONVERSION KITS

—

MATCHING ACCESSORIES

Batteries and chargers on pages 90.

B985 M

380 ML CARTRIDGE DISPENSER

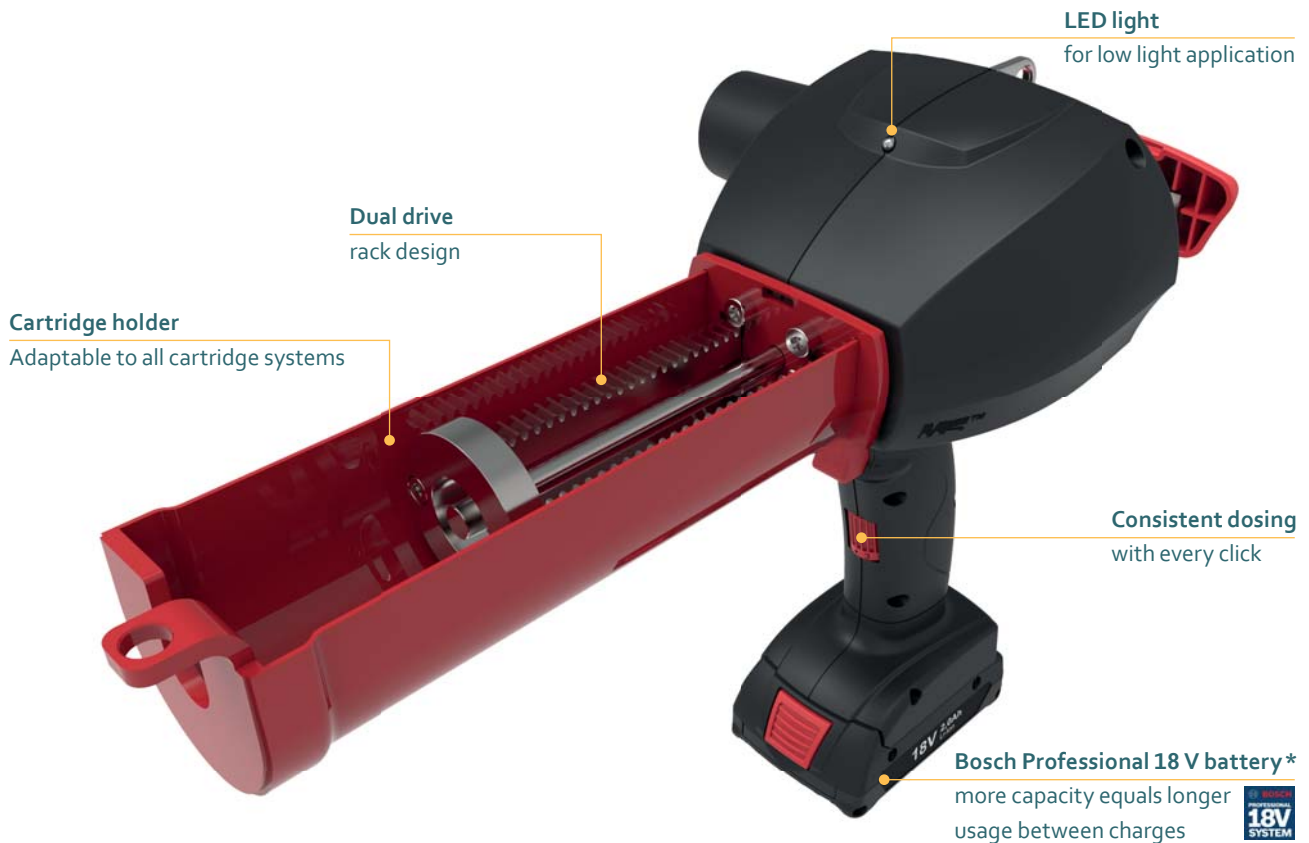

Model shown: B985 M 380 mL

FEATURES

- Unique memory function
- Dual drive rack design
- Anti-drip function
- 18 V Li-ion high performance battery
- U-opening with cartridge snap fit
- Customization possible

BENEFITS

- Consistent dosing with every click
- Reproduces quality of each adhesive
- Clean and efficient working
- Charge time: 65 min (100%)
- For easy insertion and removal of cartridges
- Customer labelling

APPLICATIONS



PRODUCT BY RANGE



B985 M

THE B985 M 2-COMPONENT BATTERY DISPENSER IS DESIGNED FOR USE WITH LOW TO MEDIUM VISCOSITY SEALANTS AND ADHESIVES. THE DUAL DRIVE RACK AND UNIQUE MEMORY FUNCTION REPRODUCES CONSISTENT DOSING EVERY TIME.

SPECIFICATIONS

- Weight: 3.3 kg / 7.3 lbs
- Cartridge Holder Length: 204 mm / 8.0 in
- Maximum Thrust: 2.75 kN (5 mm/s)
- Voltage: 18 V
- Battery Capacity: 2.0 Ah
- Battery Charge Time: 65 min (100%)
- Battery Type: Li-ion
- Handle Material: Reinforced Nylon
- Cartridge Holder Material: Steel
- Cartridge Capacity: 380 mL (13.4 oz)
- Cartridge Ratio: 10:1
- Viscosity: Low/Medium
- Standard Color: Black/Red
- Customized versions on demand

DIMENSIONS

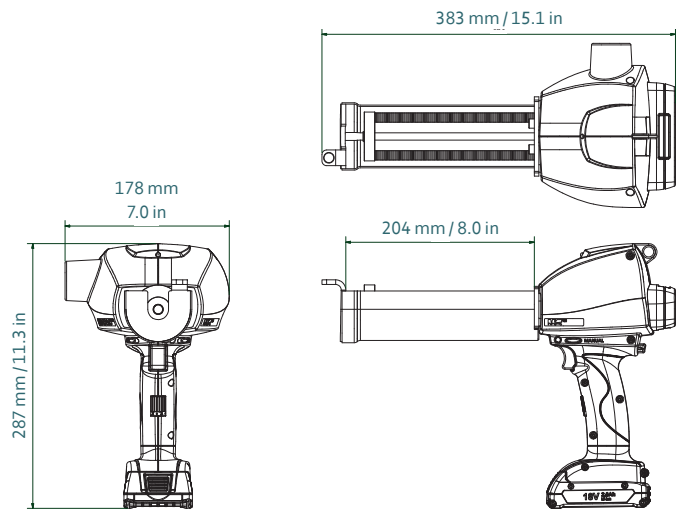

Part number	Article number	Packaging
DB2K 380-10-275-101	158093	1 per Box

MATCHING MIXPAC™ COAXIAL CARTRIDGES



Q-System
380 mL / 10:1 PA

COMPATIBLE CARTRIDGES

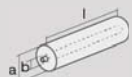

Plastic Cartridge
380 mL / 10:1 PP/PA

10:1	mm	inch
l	183.0	7.2
a	Ø 63.0	Ø 2.5
b	Ø 18.0	Ø 0.71

CONVERSION KITS

–

MATCHING ACCESSORIES

Batteries and chargers on pages 90.

B959 M

450 ML CARTRIDGE DISPENSER

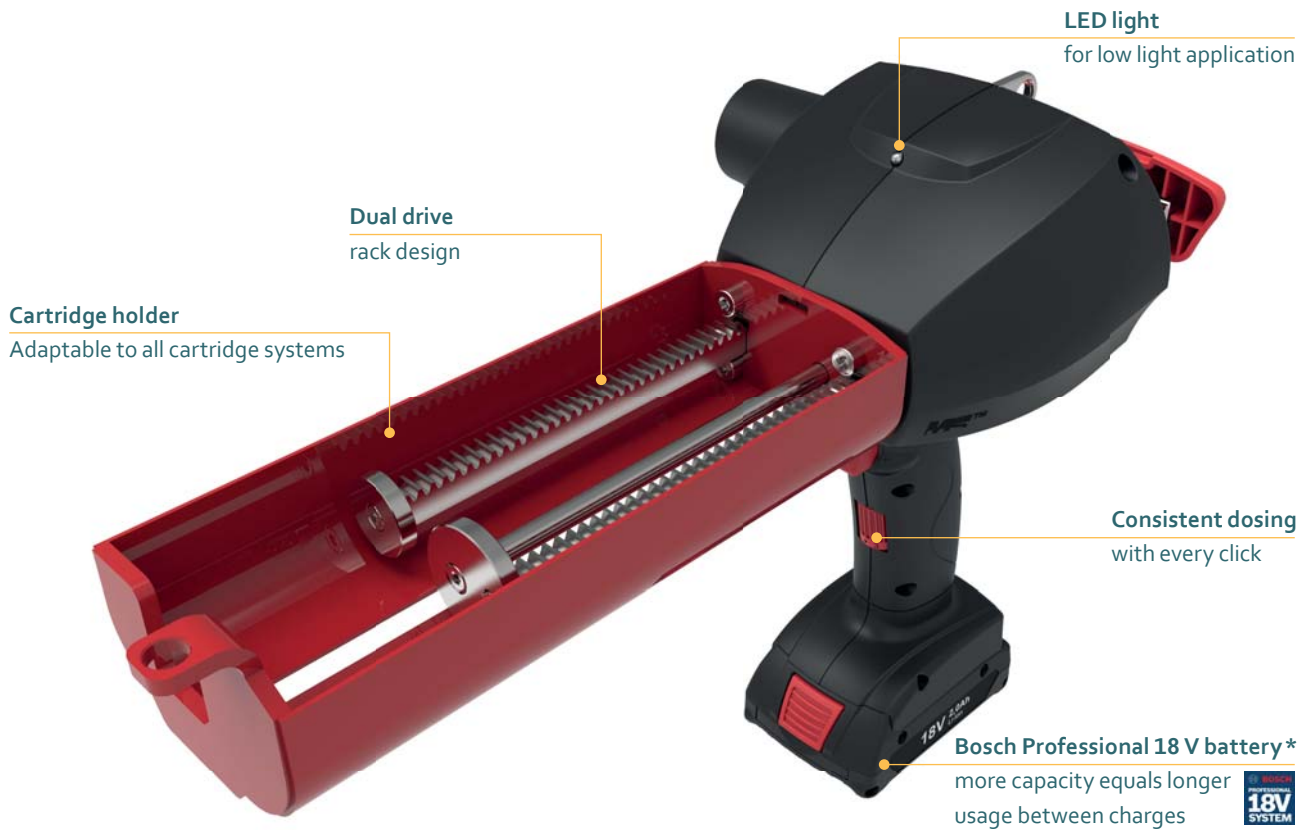

Model shown: B959 M 450 mL

FEATURES

- Unique memory function
- Dual drive rack design
- Anti-drip function
- 18 V Li-ion high performance battery
- U-opening with cartridge snap fit
- Customization possible

BENEFITS

- Consistent dosing with every click
- Reproduces quality of each adhesive
- Clean and efficient working
- Charge time: 65 min (100%)
- For easy insertion and removal of cartridges
- Customer labelling

APPLICATIONS



PRODUCT BY RANGE



B959 M

THE B959 M 2-COMPONENT BATTERY DISPENSERS U-OPENING STEEL FRAME ALLOWS FOR EASY INSERTION AND REMOVAL OF CARTRIDGES, WHILE THE DUAL DRIVE RACK AND UNIQUE MEMORY FUNCTION REPRODUCES CONSISTENT DOSING EVERY TIME.

SPECIFICATIONS

- Weight: 3.5 kg / 7.7 lbs
- Cartridge Holder Length: 229 mm / 9.0 in
- Maximum Thrust: 4.45 kN (5 mm/s)
- Voltage: 18 V
- Battery Capacity: 2.0 Ah
- Battery Charge Time: 65 min (100%)
- Battery Type: Li-ion
- Handle Material: Reinforced Nylon
- Cartridge Holder Material: Steel
- Cartridge Capacity: 450 mL (15.8 oz)
- Cartridge Ratio: 2:1
- Viscosity: Low/Medium
- Standard Color: Black/Red
- Customized versions on demand

DIMENSIONS

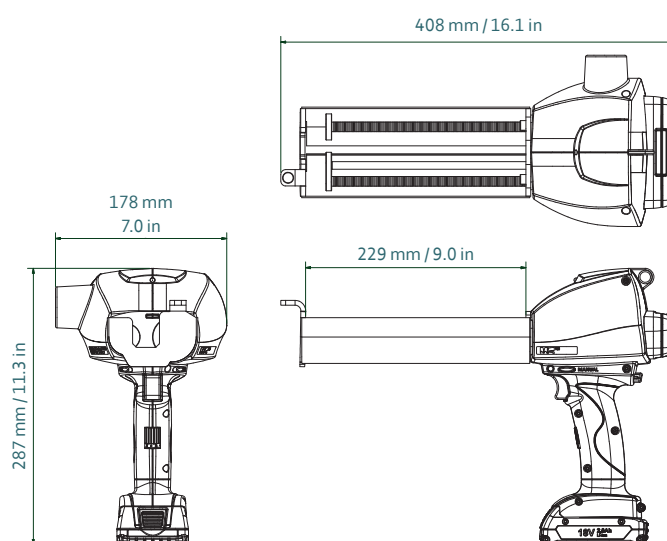

Part number	Article number	Packaging
DB2K 450-02-445-101	152611	1 per Box
DB2K 450-02-445-1US	152612 (US)	1 per Box

MATCHING MIXPAC™ COAXIAL CARTRIDGES

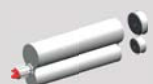

J-System
450 mL / 2:1 PA/PP

COMPATIBLE CARTRIDGES

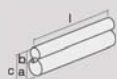

Plastic Cartridge
450 mL / 2:1 PP/PA

2:1	mm	inch
l	215.0	8.46
a	Ø 49.5	Ø 1.95
b	Ø 36.2	Ø 1.43
c	86.0	3.39

CONVERSION KITS

—

MATCHING ACCESSORIES

Batteries and chargers on pages 90.

B988 M

600 ML CARTRIDGE DISPENSER

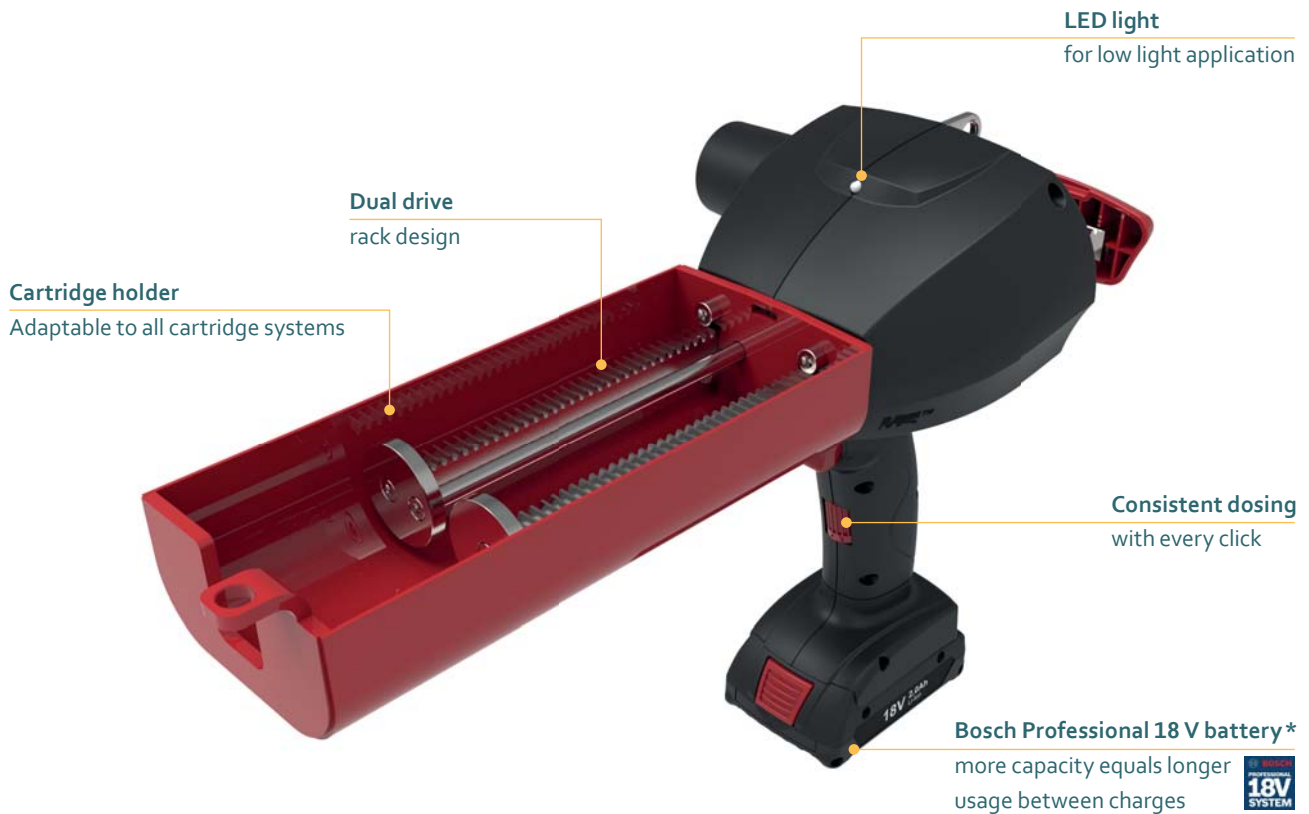

Model shown: B988 M 600 mL

FEATURES

- Unique memory function
- Dual drive rack design
- Anti-drip function
- 18 V Li-ion high performance battery
- U-opening with cartridge snap fit
- Customization possible

BENEFITS

- Consistent dosing with every click
- Reproduces quality of each adhesive
- Clean and efficient working
- Charge time: 65 min (100%)
- For easy insertion and removal of cartridges
- Customer labelling

APPLICATIONS



PRODUCT BY RANGE



B988 M

THE B988 M 2-COMPONENT BATTERY DISPENSER IS DESIGNED FOR USE WITH MEDIUM VISCOSITY SEALANTS AND ADHESIVES, WHILE THE BOSCH PROFESSIONAL 18 V RE-CHARGEABLE BATTERY OFFERS LONGER USAGE BETWEEN CHARGES.

SPECIFICATIONS

- Weight: 3.6 kg / 7.9 lbs
- Cartridge Holder Length: 234 mm / 9.2 in
- Maximum Thrust: 4.73 kN (5 mm/s)
- Voltage: 18 V
- Battery Capacity: 2.0 Ah
- Battery Charge Time: 65 min (100%)
- Battery Type: Li-ion
- Handle Material: Reinforced Nylon
- Cartridge Holder Material: Steel
- Cartridge Capacity: 600 mL (21.1 oz)
- Cartridge Ratio: 1:1
- Viscosity: Medium
- Standard Color: Black/Red
- Customized versions on demand

DIMENSIONS

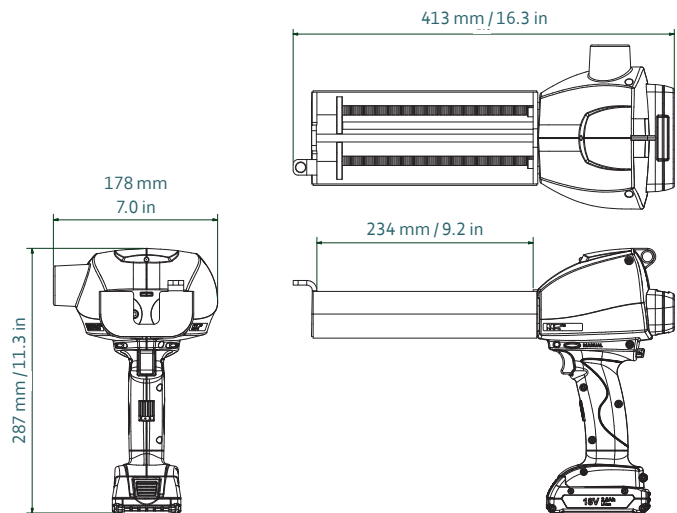

Part number	Article number	Packaging
DB2K 600-01-473-1US	152613 (US)	1 per Box
DB2K 600-01-473-101	152454	1 per Box

MATCHING MIXPAC™ SIDE-BY-SIDE CARTRIDGES



J-System
600 mL / 1:1 PP



ecopaCC
600 mL / 1:1 PP/PA

COMPATIBLE CARTRIDGES

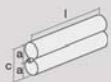

Plastic Cartridge
600 mL / 1:1 PP

1:1	mm	inch
l	217.0	8.54
a	∅ 48.0	∅ 1.89
c	95.5	3.76

CONVERSION KITS

—

MATCHING ACCESSORIES

Batteries and chargers on pages 90.

B996 M

750 ML CARTRIDGE DISPENSER

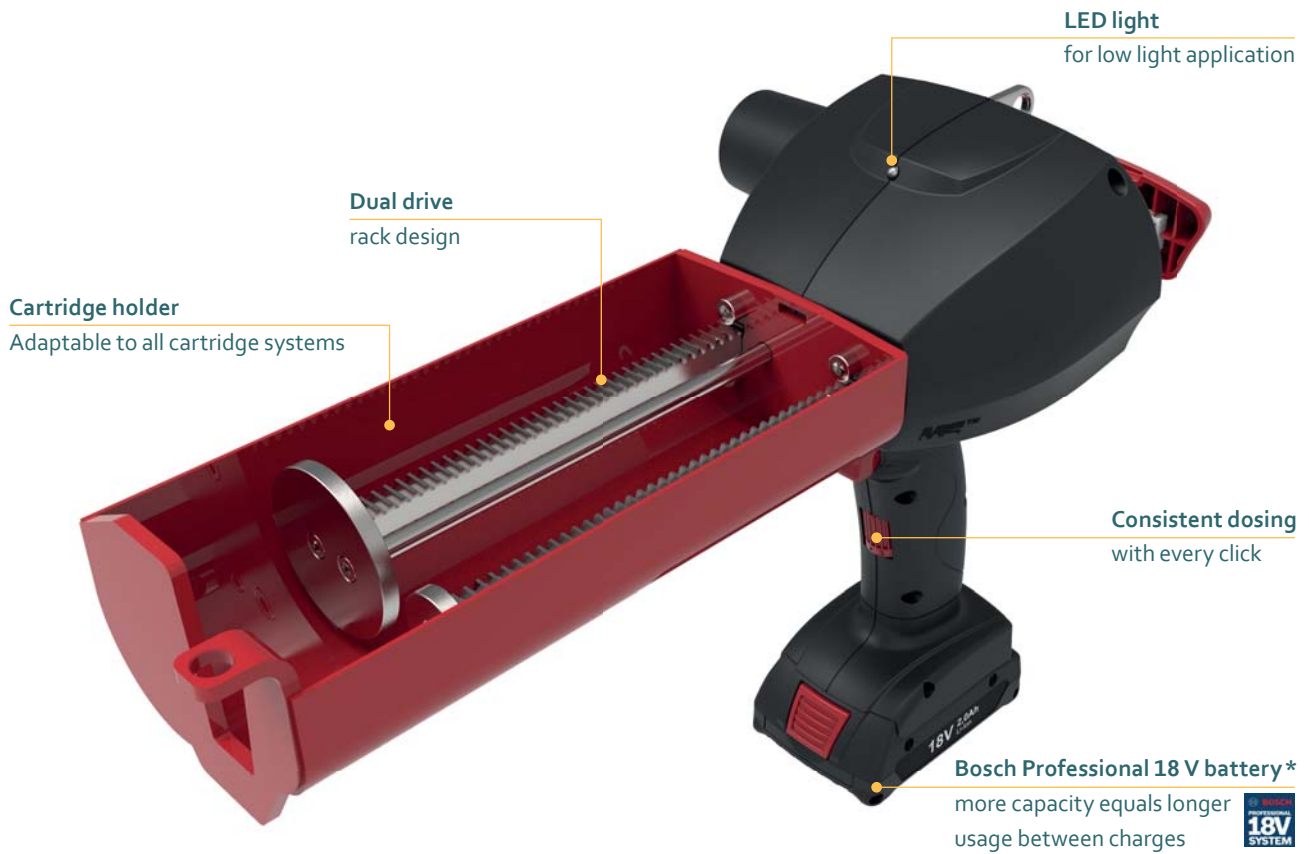

Model shown: B996 M 750 mL

FEATURES

- Unique memory function
- Dual drive rack design
- Anti-drip function
- 18 V Li-ion high performance battery
- U-opening with cartridge snap fit
- Customization possible

BENEFITS

- Consistent dosing with every click
- Reproduces quality of each adhesive
- Clean and efficient working
- Charge time: 65 min (100%)
- For easy insertion and removal of cartridges
- Customer labelling

APPLICATIONS



PRODUCT BY RANGE



B996 M

THE B996 2-COMPONENT BATTERY DISPENSER IS DESIGNED FOR USE WITH MEDIUM TO HIGH VISCOSITY SEALANTS AND ADHESIVES AND BUILT-IN ANTI-DRIP FUNCTION FOR CLEAN EFFICIENT WORKING.

SPECIFICATIONS

- Weight: 3.7 kg / 8.1 lbs
- Cartridge Holder Length: 237 mm / 9.3 in
- Maximum Thrust: 5.0 kN
- Voltage: 18 V
- Battery Capacity: 2.0 Ah
- Battery Charge Time: 65 min (100%)
- Battery Type: Li-ion
- Handle Material: Reinforced Nylon
- Cartridge Holder Material: Steel
- Cartridge Capacity: 750 mL (25.4 oz)
- Cartridge Ratio: 4:1
- Viscosity: Low/Medium
- Standard Color: Black/Red
- Customized versions on demand

DIMENSIONS

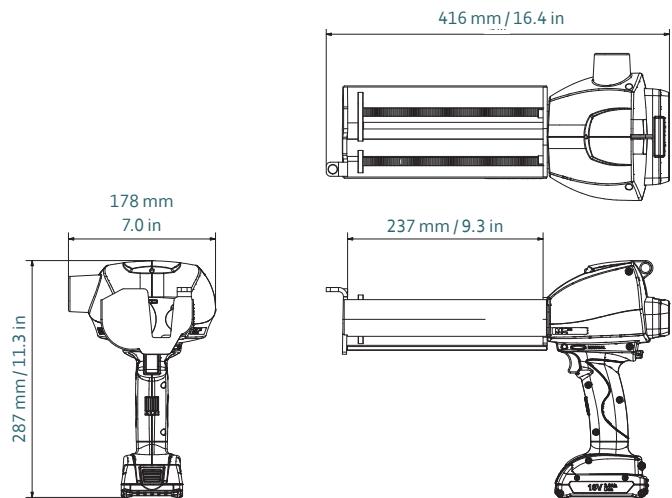

Part number	Article number	Packaging
DB2K 750-04-500-001	178345	1 per Box

MATCHING MIXPAC™ CARTRIDGES

COMPATIBLE CARTRIDGES

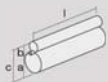

Plastic Cartridge
750 mL / 4:1 PP

4:1	mm	inch
l	217.0	8.54
a	∅ 68.0	∅ 2.68
b	∅ 34.0	∅ 1.34
c	102.0	4.0

CONVERSION KITS

MATCHING ACCESSORIES

Batteries and chargers on pages 90.

B998 M

825 ML CARTRIDGE DISPENSER

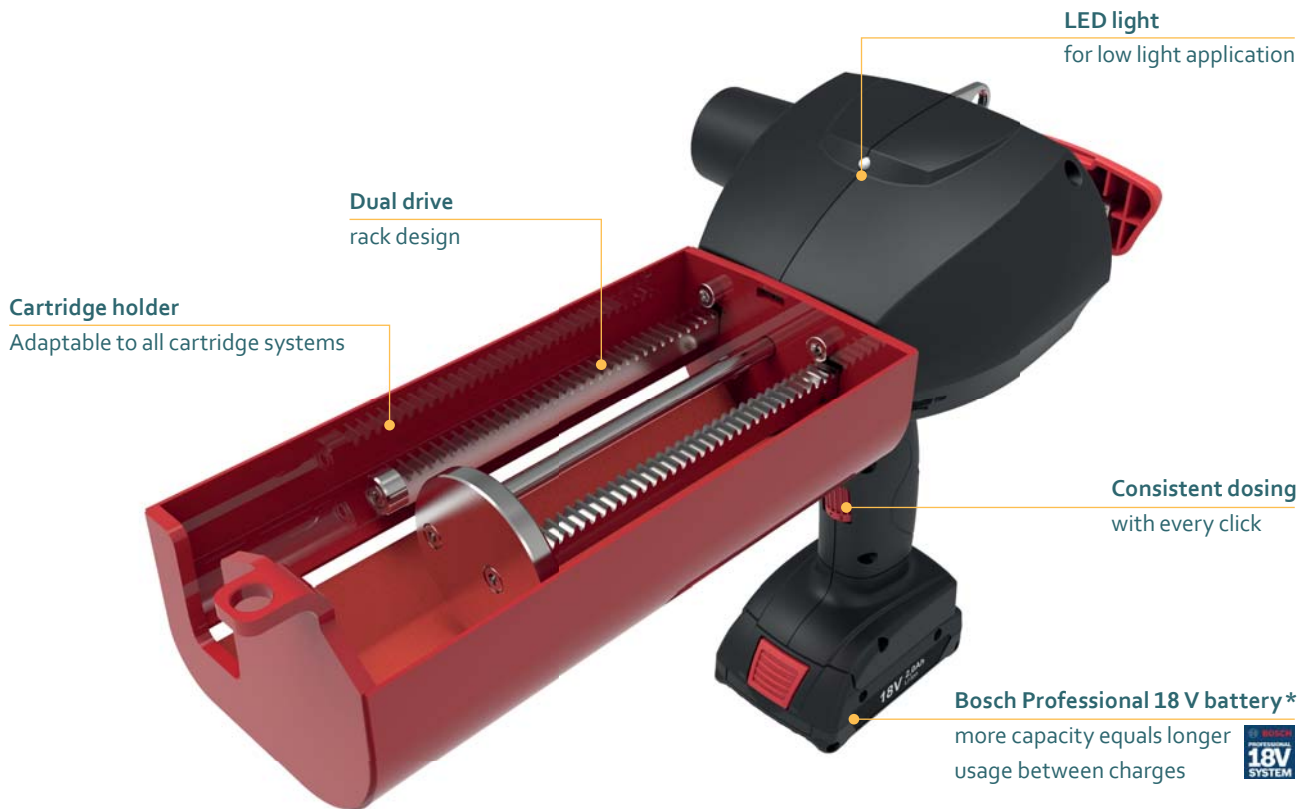

Model shown: B998 M 825 mL

FEATURES

- Unique memory function
- Dual drive rack design
- Anti-drip function
- 18 V Li-ion high performance battery
- U-opening with cartridge snap fit
- Customization possible

BENEFITS

- Consistent dosing with every click
- Reproduces quality of each adhesive
- Clean and efficient working
- Charge time: 65 min (100%)
- For easy insertion and removal of cartridges
- Customer labelling

APPLICATIONS



PRODUCT BY RANGE



B998 M

THE B998 M 2-COMPONENT BATTERY DISPENSER DUAL DRIVE RACK AND UNIQUE MEMORY FUNCTION REPRODUCES CONSISTENT DOSING EVERY TIME, WHILE THE BOSCH PROFESSIONAL 18 V RE-CHARGEABLE BATTERY OFFERS LONGER USAGE BETWEEN CHARGES.

SPECIFICATIONS

- Weight: 3.7 kg / 8.1 lbs
- Cartridge Holder Length: 232 mm / 9.1 in
- Maximum Thrust: 5 kN (5 mm/s)
- Voltage: 18 V
- Battery Capacity: 2.0 Ah
- Battery Charge Time: 65 min (100%)
- Battery Type: Li-ion
- Handle Material: Reinforced Nylon
- Cartridge Holder Material: Steel
- Cartridge Capacity: 825 mL (29 oz)
- Cartridge Ratio: 10:1
- Viscosity: Medium
- Standard Color: Black/Red
- Customized versions on demand

DIMENSIONS

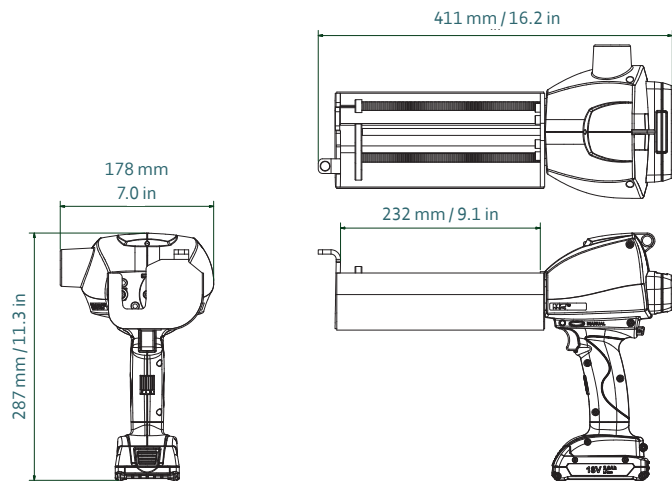

Part number	Article number	Packaging
DB2K 825-10-500-101	152614	1 per Box
DB2K 825-10-500-1US	152615 (US)	1 per Box

MATCHING MIXPAC™ SIDE-BY-SIDE CARTRIDGES



J-System
825 mL / 10:1 PA

COMPATIBLE CARTRIDGES

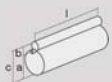

Plastic Cartridge
825 mL / 10:1 PP

10:1	mm	inch
l	216.0	8.5
a	Ø 80.7	Ø 3.18
b	Ø 28.6	Ø 1.13
c	109.0	4.29

CONVERSION KITS

—

MATCHING ACCESSORIES

Batteries and chargers on pages 90.

B939 M

900 ML CARTRIDGE DISPENSER

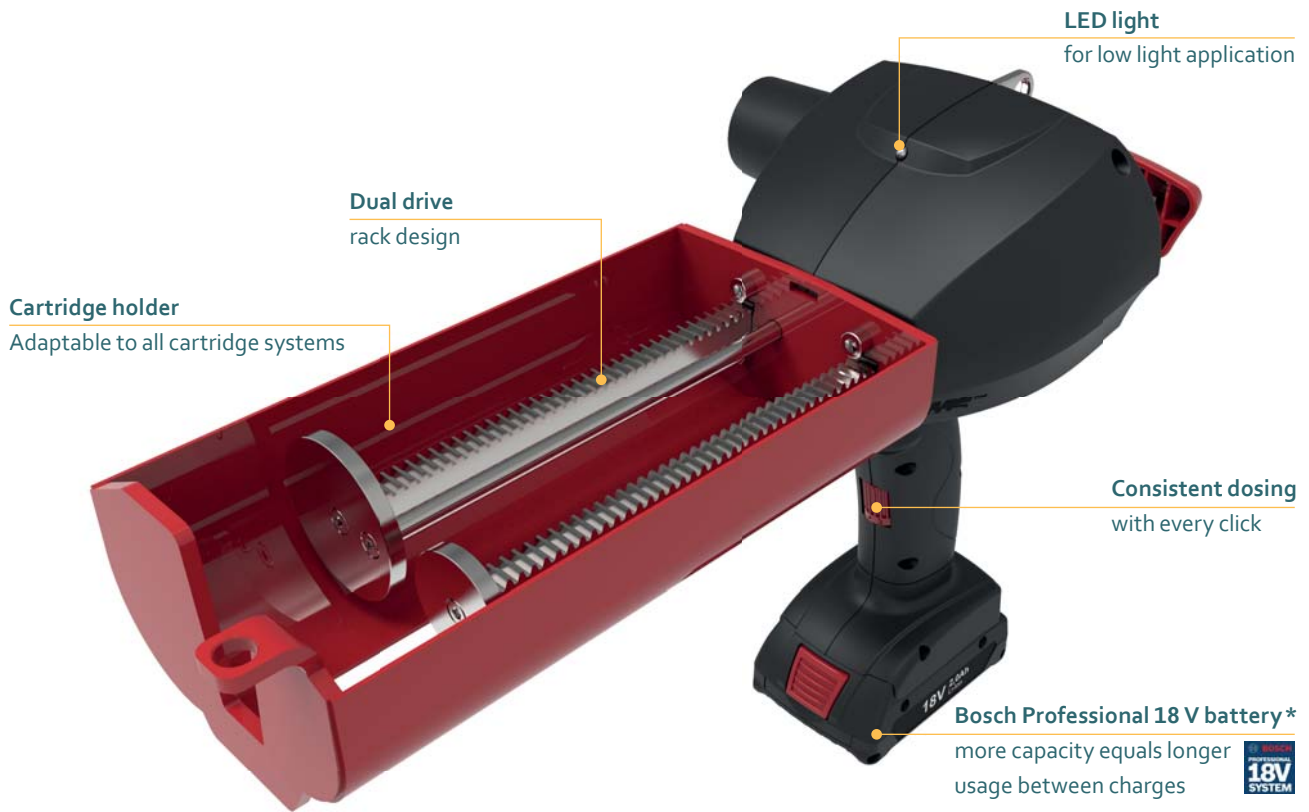

Model shown: B939 M 900 mL

FEATURES

- Unique memory function
- Dual drive rack design
- Anti-drip function
- 18 V Li-ion high performance battery
- U-opening with cartridge snap fit
- Customization possible

BENEFITS

- Consistent dosing with every click
- Reproduces quality of each adhesive
- Clean and efficient working
- Charge time: 65 min (100%)
- For easy insertion and removal of cartridges
- Customer labelling

APPLICATIONS



PRODUCT BY RANGE



B939 M

THE B939 2-COMPONENT BATTERY DISPENSER IS DESIGNED FOR USE WITH MEDIUM TO HIGH VISCOSITY SEALANTS AND ADHESIVES, WHILE THE BOSCH PROFESSIONAL 18 V RE-CHARGEABLE BATTERY OFFERS LONGER USAGE BETWEEN CHARGES.

SPECIFICATIONS

- Weight: 3.5 kg / 7.7 lbs
- Cartridge Holder Length: 237 mm / 9.3 in
- Maximum Thrust: 5.0 kN (5 mm/s)
- Voltage: 18 V
- Battery Capacity: 2.0 Ah
- Battery Charge Time: 65 min (100%)
- Battery Type: Li-ion
- Handle Material: Reinforced Nylon
- Cartridge Holder Material: Steel
- Cartridge Capacity: 900 mL (30.4 oz)
- Cartridge Ratio: 2:1
- Viscosity: Medium/High
- Standard Color: Black/Red
- Customized versions on demand

DIMENSIONS

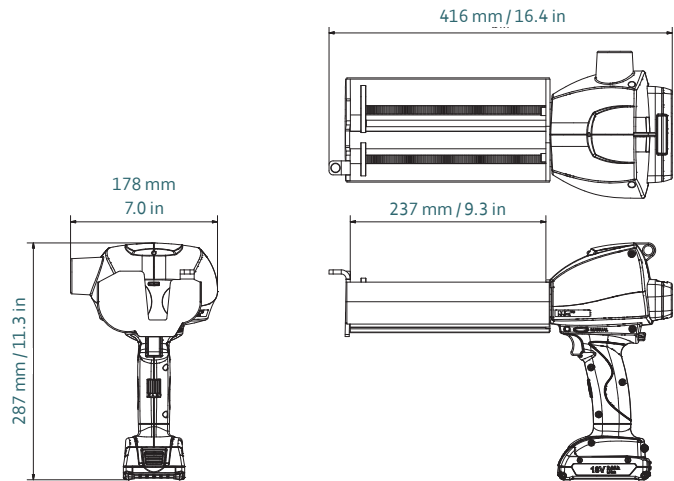

Part number	Article number	Packaging
DB2K 900-02-500-001	178336	1 per Box

MATCHING MIXPAC™ CARTRIDGES

COMPATIBLE CARTRIDGES



Plastic Cartridge
900 mL / 2:1 PP/PA

2:1	mm	inch
l	215.0	8.46
a	Ø 69.0	Ø 2.72
b	Ø 50.0	Ø 1.97
c	119.0	4.69

CONVERSION KITS

MATCHING ACCESSORIES

Batteries and chargers on pages 90.

B999 M

1500 ML CARTRIDGE DISPENSER

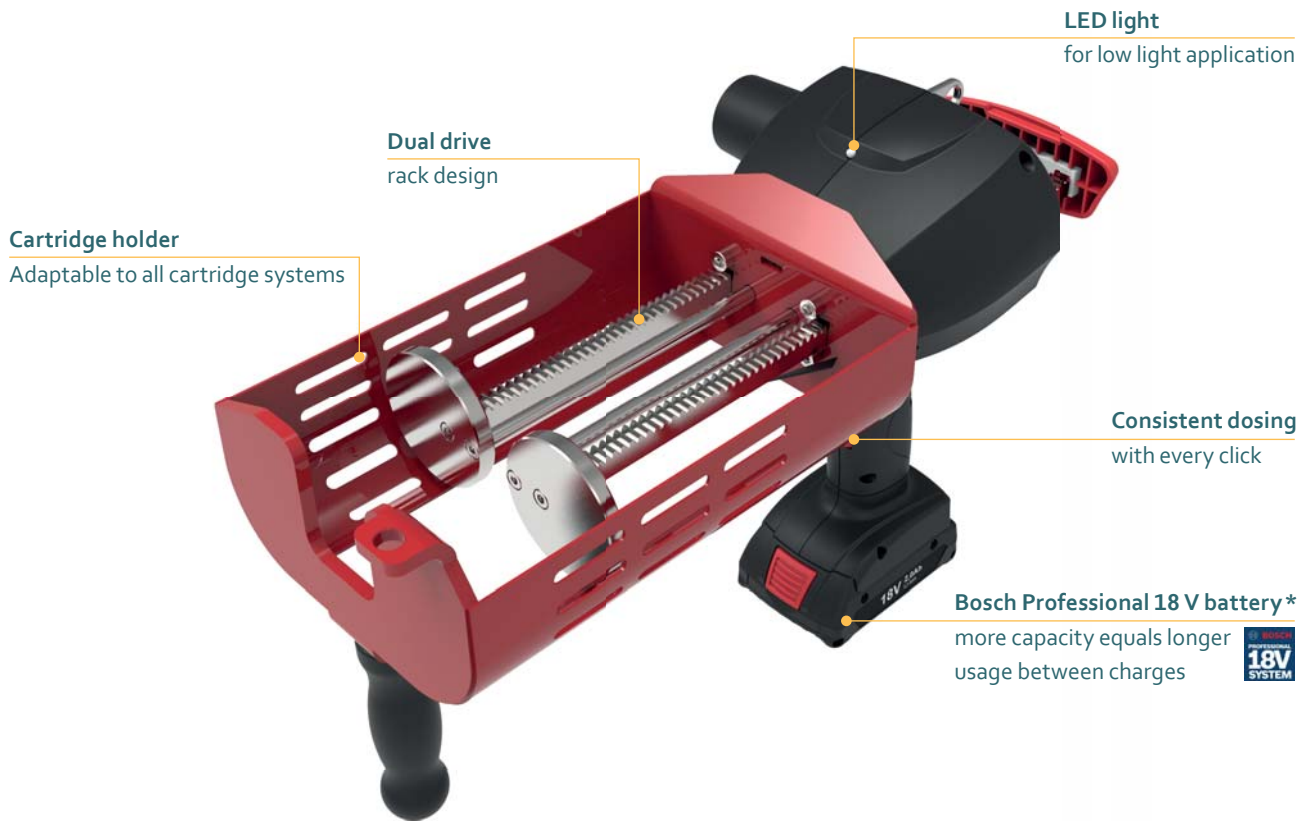

Model shown: B999 M 1500 mL

FEATURES

- Unique memory function
- Dual drive rack design
- Anti-drip function
- 18 V Li-ion high performance battery
- U-opening with cartridge snap fit
- Customization possible

BENEFITS

- Consistent dosing with every click
- Reproduces quality of each adhesive
- Clean and efficient working
- Charge time: 65 min (100%)
- For easy insertion and removal of cartridges
- Customer labelling

APPLICATIONS



PRODUCT BY RANGE



B999 M

THE B999 M 2-COMPONENT BATTERY DISPENSER DUAL DRIVE RACK AND UNIQUE MEMORY FUNCTION REPRODUCES CONSISTENT DOSING EVERY TIME. ACCIDENTAL MATERIAL DISCHARGE IS PREVENTED WITH THE BUILT-IN ANTI-DRIP MECHANISM.

SPECIFICATIONS

- Weight: 4.2 kg / 7.9 lbs
- Cartridge Holder Length: 233 mm / 9.2 in
- Maximum Thrust: 5 kN (5 mm/s)
- Voltage: 18 V
- Battery Capacity: 2.0 Ah
- Battery Charge Time: 65 min (100%)
- Battery Type: Li-ion
- Handle Material: Reinforced Nylon
- Cartridge Holder Material: Steel
- Cartridge Capacity: 1500 mL (52.8 oz)
- Cartridge Ratio: 1:1
- Viscosity: Medium
- Standard Color: Black/Red
- Customized versions on demand

DIMENSIONS

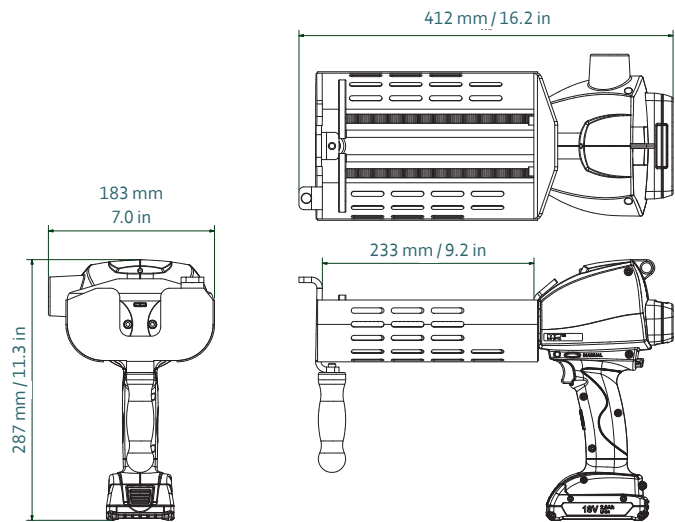

Part number	Article number	Packaging
DB2K 1500-01-500-01	152616	1 per Box
DB2K 1500-01-500-1US	152617 (US)	1 per Box

MATCHING MIXPAC™ SIDE-BY-SIDE CARTRIDGES

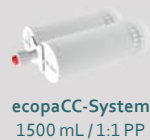
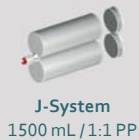

COMPATIBLE CARTRIDGES



1:1	mm	inch
l	215.0	8.46
a	Ø 79.0	Ø 3.11
c	160.0	6.3

CONVERSION KITS

–

MATCHING ACCESSORIES

Batteries and chargers on pages 90.

TS408 HM-101

50 ML CARTRIDGE DISPENSER

Quick cartridge exchange
for efficient working

Simple dispensing
one hand speed adjustment

Reinforced nylon handle
compact and lightweight



Model shown: TS408 HM-101 50 mL

FEATURES

- Quick cartridge exchange
- One hand pressure adjustment
- Anti-drip function
- Reinforced nylon handle
- Customization possible

BENEFITS

- For efficient working
- Simple dispensing, effective working
- Clean application
- Compact and lightweight
- Customer labelling

APPLICATIONS



Bonding

PRODUCT BY RANGE



THE TS408 HM-101 2-COMPONENT PNEUMATIC DISPENSER OFFERS QUICK CARTRIDGE EXCHANGE FOR EFFICIENT WORKING ACROSS ALL YOUR APPLICATIONS WHILE THE ANTI-DRIP FUNCTION MAKES FOR EASY AND CLEAN DISPENSING.

SPECIFICATIONS

- Light weight: 0.73 kg / 1.6 lbs
- Dispenser Length: 184 mm / 7.2 in
- Maximum Thrust: 1.3 kN
- Maximum Pneumatic Pressure: 8 bar / 116 psi
- Air Consumption: 40 litres/min
- Handle Material: Reinforced Nylon
- Cartridge Holder Material: Reinforced Nylon
- Cartridge Capacity: 50 mL (1.8 oz)
- Cartridge Ratio: 10:1
- Viscosity: Low
- Standard Color: Black
- Customized versions on demand

DIMENSIONS

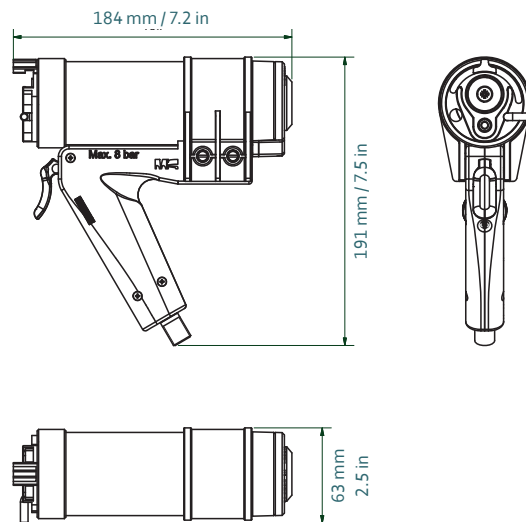

Part number	Article number	Packaging
DP2K S50-10-130-001	151886	1 per Box

MATCHING MIXPAC™ SIDE-BY-SIDE CARTRIDGES



BS-System
50 mL / 10:1 PP/PBT

COMPATIBLE SIDE-BY-SIDE CARTRIDGES

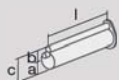

Round Flange Cartridge
50 mL / 10:1 PP/PBT

10:1	mm	inch
l	102.0	4.02
a	Ø 30.0	Ø 1.18
b	Ø 10.8	Ø 0.43
c	44.0	1.73

CONVERSION KITS

MATCHING ACCESSORIES

TS408 MY-8

50 ML CARTRIDGE DISPENSER

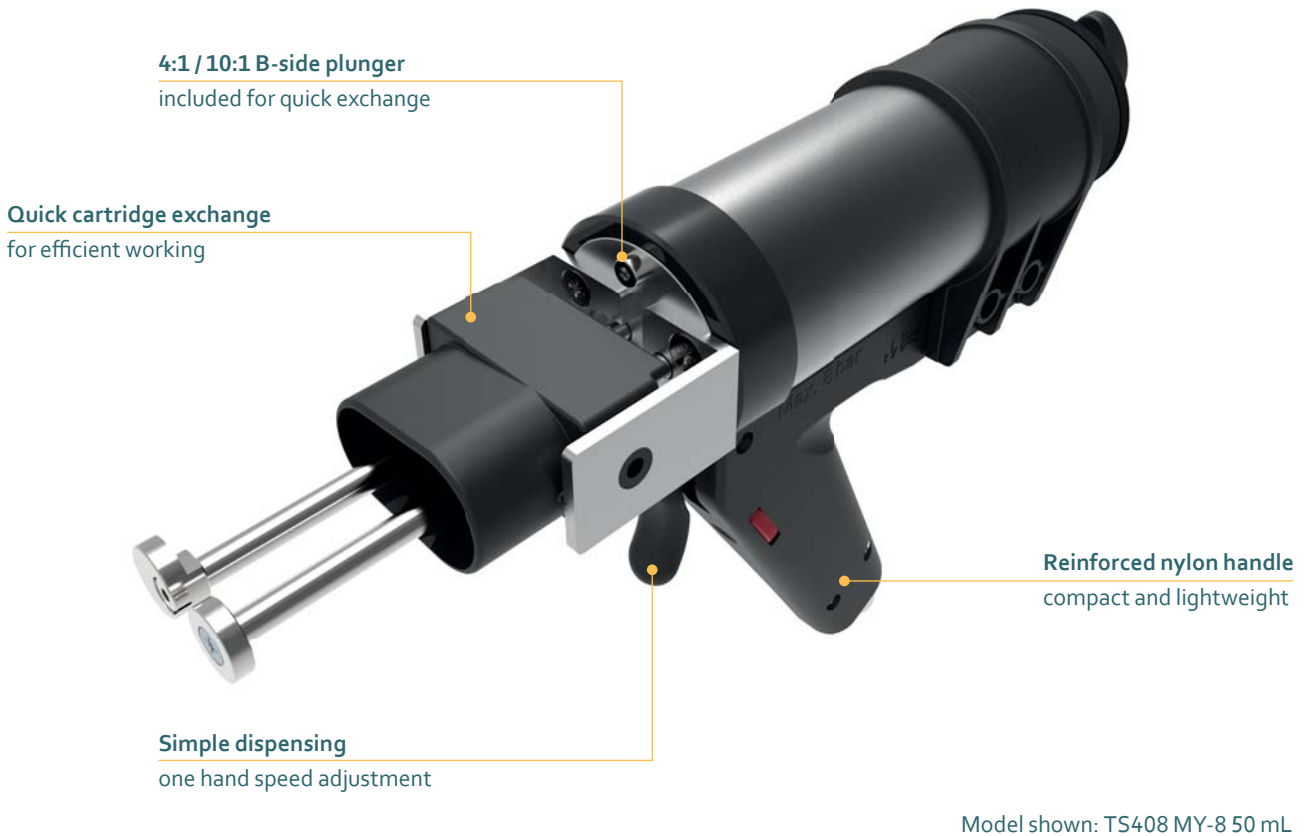

FEATURES

- Quick cartridge exchange
- One hand pressure adjustment
- Anti-drip function
- Reinforced nylon handle
- Customization possible

BENEFITS

- For efficient working
- Simple dispensing, effective working
- Clean application
- Compact and lightweight
- Customer labelling

APPLICATIONS



Bonding

PRODUCT BY RANGE



THE TS408 MY-8 2-COMPONENT PNEUMATIC DISPENSERS ONE-HANDED PRESSURE ADJUSTMENT ALLOWS FOR SIMPLE EFFECTIVE OPERATION WHILE THE QUICK CARTRIDGE EXCHANGE OFFERS EFFICIENT WORKING ACROSS ALL YOUR APPLICATIONS.

SPECIFICATIONS

- Lightweight: 0.73 kg / 1.6 lbs
- Dispenser Length: 303 mm / 11.9 in
- Maximum Thrust: 1.3 kN
- Maximum Pneumatic Pressure: 8 bar / 116 psi
- Air Consumption: 40 litres/min
- Handle Material: Reinforced Nylon
- Cartridge Holder Material: Reinforced Nylon
- Cartridge Capacity: 50 mL (1.8 oz), 75 mL (2.7 oz)
- Cartridge Ratios: 1:1, 2:1, 4:1, 10:1
- Viscosity: High
- Standard Color: Black
- Customized versions on demand

DIMENSIONS

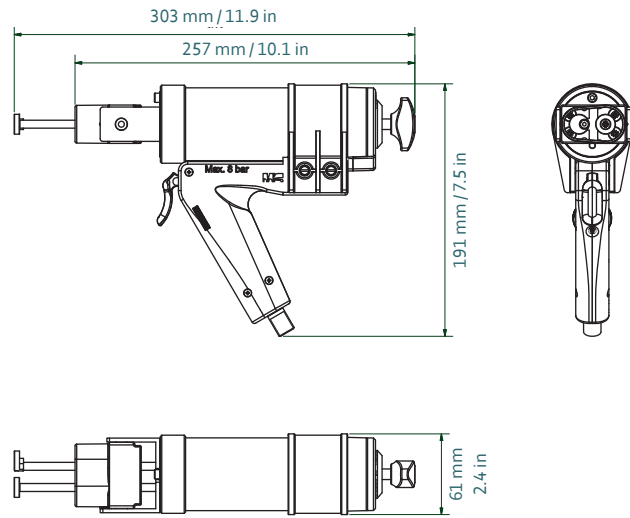

Part number	Article number	Packaging
DP2K 050-MR-130-001	151780 (50 mL)	1 per Box

MATCHING MIXPAC™ SIDE-BY-SIDE CARTRIDGES



A-System
50 mL / 1:1 PP/PA



B-System
50 mL / 1:1 PP/PA



A-System
50 mL / 2:1 PP/PA



B-System
50 mL / 2:1 PP/PA



A-System
50 mL / 4:1 PP/PA



A-System
50 mL / 10:1 PP/PA

COMPATIBLE CARTRIDGES

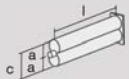

Rectangular Flange Cartridge
50 mL / 1:1 PP/PBT



Rectangular Flange Cartridge
50 mL / 2:1 PP/PBT

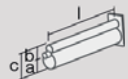

Rectangular Flange Cartridge
50 mL / 4:1 PP/PBT

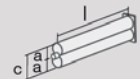

Rectangular Flange Cartridge
50 mL / 10:1 PP/PBT

	1:1	mm	inch	2:1	mm	inch	4:1	mm	inch	10:1	mm	inch
l		99.7	3.93	l	108.5	4.27	l	108.5	4.27	l	102.0	4.02
a		Ø 21.0	Ø 0.83	a	Ø 25.0	Ø 0.89	a	Ø 25.0	Ø 0.89	a	Ø 30.0	Ø 1.18
c		46.0	1.81	b	Ø 18.0	Ø 0.71	b	Ø 13.0	Ø 0.51	b	Ø 10.8	Ø 0.43
				c	46.0	1.81	c	46.0	1.81	c	44.0	1.73

CONVERSION KITS

MATCHING ACCESSORIES

TS408 M-75

75 ML CARTRIDGE DISPENSER



Model shown: TS408 M-75 75 mL

FEATURES

- Quick cartridge exchange
- One hand pressure adjustment
- Anti-drip function
- Reinforced nylon handle
- Customization possible

BENEFITS

- For efficient working
- Simple dispensing, effective working
- Clean application
- Compact and lightweight
- Customer labelling

APPLICATIONS



Bonding

PRODUCT BY RANGE



THE TS408 M-75 2-COMPONENT PNEUMATIC DISPENSERS ONE-HANDED PRESSURE ADJUSTMENT ALLOWS FOR SIMPLE EFFECTIVE OPERATION WHILE THE QUICK CARTRIDGE EXCHANGE OFFERS EFFICIENT WORKING ACROSS ALL YOUR APPLICATIONS.

SPECIFICATIONS

- Lightweight: 0.73 kg / 1.6 lbs
- Dispenser Length: 390 mm / 11.9 in
- Maximum Thrust: 1.3 kN
- Maximum Pneumatic Pressure: 8 bar / 116 psi
- Air Consumption: 40 litres/min
- Handle Material: Reinforced Nylon
- Cartridge Holder Material: Reinforced Nylon
- Cartridge Capacity: 75 mL (2.7 oz)
- Cartridge Ratio: 1:1
- Viscosity: High
- Standard Color: Black
- Customized versions on demand

DIMENSIONS

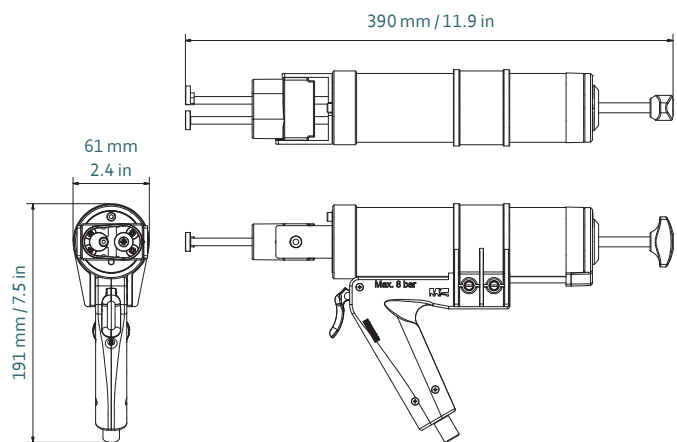

Part number	Article number	Packaging
DP2K 075-MR-130-001	153098 (75 mL)	1 per Box

MATCHING MIXPAC™ SIDE-BY-SIDE CARTRIDGES



A-System
75 mL / 1:1 PP/PA

COMPATIBLE CARTRIDGES

—

CONVERSION KITS

—

MATCHING ACCESSORIES

—

TS408 EM

50 ML CARTRIDGE DISPENSER

Quick cartridge exchange
for efficient working



Simple dispensing
one hand speed adjustment

Reinforced nylon handle
compact and lightweight

Model shown: TS408 EM 50 mL

FEATURES

- Quick cartridge exchange
- One hand pressure adjustment
- Anti-drip function
- Reinforced nylon handle
- Customization possible

BENEFITS

- For efficient working
- Simple dispensing, effective working
- Clean application
- Compact and lightweight
- Customer labelling

APPLICATIONS



Bonding

PRODUCT BY RANGE



T408 HM-101

TS408 MY-8

TS408 M-75

TS408 EM

TS408 BM

THE TS408 EM 2-COMPONENT PNEUMATIC DISPENSERS ONE-HANDED PRESSURE ADJUSTMENT ALLOWS FOR SIMPLE EFFECTIVE OPERATION, WHILE THE ANTI-DRIP FUNCTION MAKES FOR EASY AND CLEAN DISPENSING.

SPECIFICATIONS

- Lightweight: 0.73 kg / 1.6 lbs
- Dispenser Length: 232 mm / 9.1 in
- Maximum Thrust: 1.3 kN
- Maximum Pneumatic Pressure: 8 bar / 116 psi
- Air Consumption: 40 litres/min
- Handle Material: Reinforced Nylon
- Cartridge Holder Material: Reinforced Nylon
- Cartridge Capacity: 50 mL (1.8 oz)
- Cartridge Ratios: 1:1, 2:1, 3:2
- Viscosity: High
- Standard Color: Black
- Customized versions on demand

DIMENSIONS

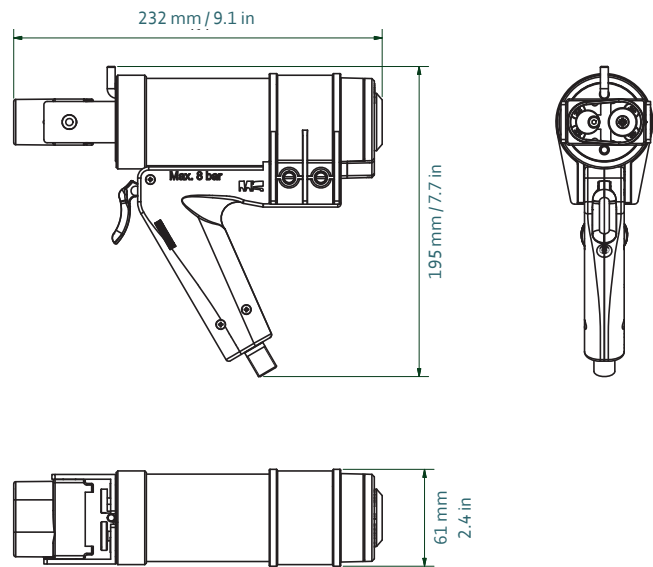

Part number	Article number	Packaging
DP2K 050-12-130-101	151781	1 per Box

MATCHING MIXPAC™ SIDE-BY-SIDE CARTRIDGES

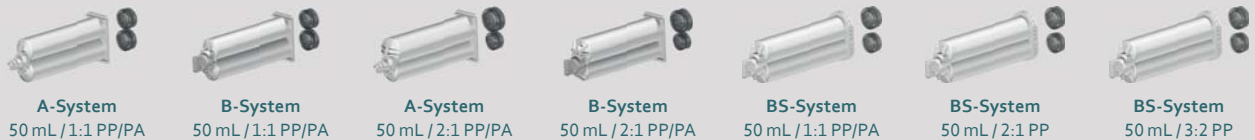

COMPATIBLE CARTRIDGES

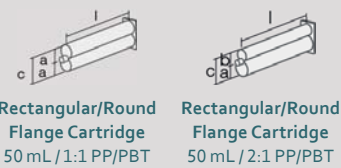

1:1		2:1	
mm	inch	mm	inch
l	99.7	108.5	4.27
a	∅ 21.0	∅ 25.0	∅ 0.89
c	46.0	∅ 18.0	∅ 0.71
		c	46.0

CONVERSION KITS

MATCHING ACCESSORIES

TS408 BM

50 ML CARTRIDGE DISPENSER



Model shown: TS408 BM 50 mL

FEATURES

- Quick cartridge exchange
- One hand pressure adjustment
- Anti-drip function
- Reinforced nylon handle
- Customization possible

BENEFITS

- For efficient working
- Simple dispensing, effective working
- Clean application
- Compact and lightweight
- Customer labelling

APPLICATIONS



Bonding

PRODUCT BY RANGE



THE TS408 BM 2-COMPONENT PNEUMATIC DISPENSERS ANTI-DRIP FUNCTION MAKES FOR EASY AND CLEAN DISPENSING. A ONE-HANDED PRESSURE ADJUSTMENT ALLOWS FOR SIMPLE EFFECTIVE OPERATION.

SPECIFICATIONS

- Lightweight: 0.73 kg / 1.6 lbs
- Dispenser Length: 344 mm / 13.5 in
- Maximum Thrust: 1.3 kN
- Maximum Pneumatic Pressure: 8 bar / 116 psi
- Air Consumption: 40 litres/min
- Handle Material: Reinforced Nylon
- Cartridge Holder Material: Reinforced Nylon
- Cartridge Capacity: 50 mL (1.8 oz)
- Cartridge Ratio: 4:1, 10:1
- Viscosity: High
- Standard Color: Black
- Customized versions on demand

DIMENSIONS

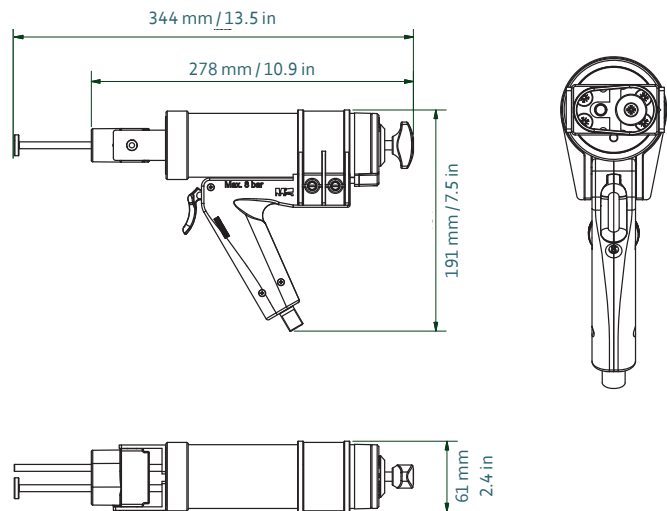

Part number	Article number	Packaging
DP2K 050-41-130-001	153094	1 per Box

MATCHING MIXPAC™ SIDE-BY-SIDE CARTRIDGES

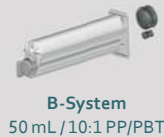
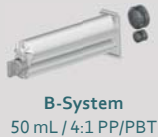

COMPATIBLE CARTRIDGES

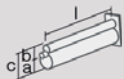

Rectangular Flange Cartridge
50 mL / 4:1 PP/PBT

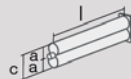

Rectangular Flange Cartridge
50 mL / 10:1 PP/PBT

4:1	mm	inch
l	108.5	4.27
a	∅ 25.0	∅ 0.89
b	∅ 13.0	∅ 0.51
c	46.0	1.81

10:1	mm	inch
l	102.0	4.02
a	∅ 30.0	∅ 1.18
b	∅ 10.8	∅ 0.43
c	44.0	1.73

CONVERSION KITS

MATCHING ACCESSORIES

TS483 XM

400 ML CARTRIDGE DISPENSER



Simple dispensing
one hand speed adjustment

Compact reinforced
nylon handle

Air operated plunger retraction
rapid reset/reload

Model shown: TS483 XM 400 mL

FEATURES

- Air operated plunger retraction
- One hand pressure adjustment
- Anti-drip function
- Long life technology
- Customization possible

BENEFITS

- Quick cartridge exchange
- Simple dispensing speed adjustment
- Clean application
- Precise working
- Customer labelling

APPLICATIONS



PRODUCT BY RANGE



THE TS483 XM IS A 2-COMPONENT PNEUMATIC DISPENSER DESIGNED FOR USE WITH MEDIUM TO HIGH VISCOSITY SEALANTS AND ADHESIVES. A ONE-HANDED PRESSURE ADJUSTMENT ALLOWS FOR SIMPLE EFFECTIVE OPERATION.

SPECIFICATIONS

- Lightweight: 2.6 kg / 5.6 lbs
- Cartridge Holder Length: 203 mm / 8.0 in
- Maximum Thrust: 4 kN
- Maximum Pneumatic Pressure: 8 bar / 116 psi
- Air Consumption: 40 litres/min
- Handle Material: Reinforced Nylon
- Cartridge Holder Material: Aluminum
- Frame Material: Steel
- Cartridge Capacity: 400 mL (14.1 oz)
- Cartridge Ratio: 1:1
- Viscosity: Medium/High
- Standard Color: Black/Red
- Customized versions on demand

DIMENSIONS

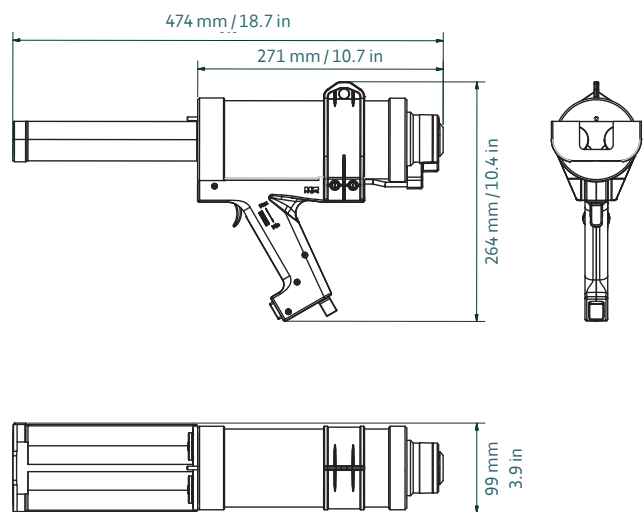

Part number	Article number	Packaging
DP2K 400-01-400-001	152309	1 per Box

MATCHING MIXPAC™ SIDE-BY-SIDE CARTRIDGES

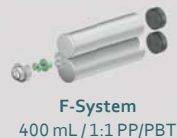
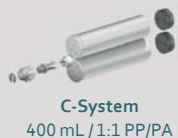

COMPATIBLE SIDE-BY-SIDE CARTRIDGES

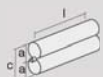

Plastic Cartridge
400 mL / 1:1 PP/PBT

1:1	mm	inch
l	185.0	7.28
a	Ø 45.0	Ø 1.77
c	93.0	3.66

CONVERSION KITS

MATCHING ACCESSORIES

TS483 LXM

400 ML CARTRIDGE DISPENSER



Model shown: TS483 LXM 400 mL

FEATURES

- Air operated plunger retraction
- One hand pressure adjustment
- Anti-drip function
- Long life technology
- Customization possible

BENEFITS

- Quick cartridge exchange
- Simple dispensing speed adjustment
- Clean application
- Precise working
- Customer labelling

APPLICATIONS



PRODUCT BY RANGE



THE TS483 LXM 2-COMPONENT PNEUMATIC DISPENSERS QUICK CARTRIDGE EXCHANGE OFFERS EFFICIENT WORKING ACROSS ALL YOUR APPLICATIONS. THE ANTI-DRIP FUNCTION MAKES FOR EFFICIENT DISPENSING.

SPECIFICATIONS

- Lightweight: 2.6 kg / 5.6 lbs
- Cartridge Holder Length: 201 mm / 7.9 in
- Maximum Thrust: 2.7 kN
- Maximum Pneumatic Pressure: 8 bar / 116 psi
- Air Consumption: 40 litres/min
- Handle Material: Reinforced Nylon
- Cartridge Holder Material: Aluminum
- Frame Material: Steel
- Cartridge Capacity: 400 mL (14.1 oz)
- Cartridge Ratio: 1:1
- Viscosity: Low/Medium
- Standard Color: Black/Red
- Customized versions on demand

DIMENSIONS

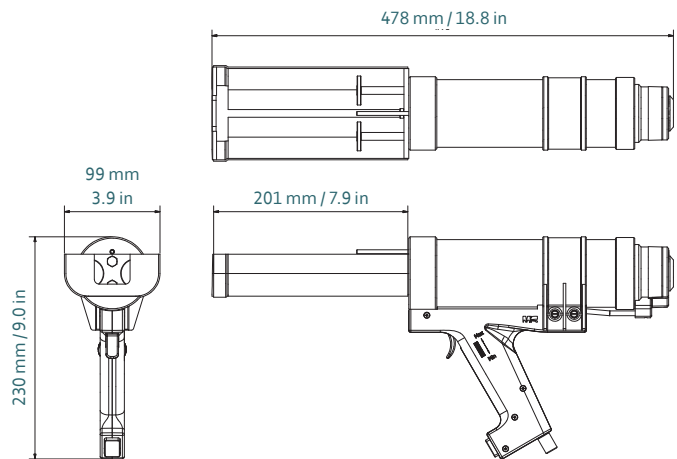

Part number	Article number	Packaging
DP2K 400-01-270-001	151788	1 per Box

MATCHING MIXPAC™ SIDE-BY-SIDE CARTRIDGES

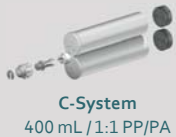

COMPATIBLE SIDE-BY-SIDE CARTRIDGES

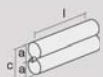

Plastic Cartridge
400 mL / 1:1 PP/PBT

1:1	mm	inch
l	185.0	7.28
a	Ø 45.0	Ø 1.77
c	93.0	3.66

CONVERSION KITS

MATCHING ACCESSORIES

TS459 LXS

450 ML CARTRIDGE DISPENSER

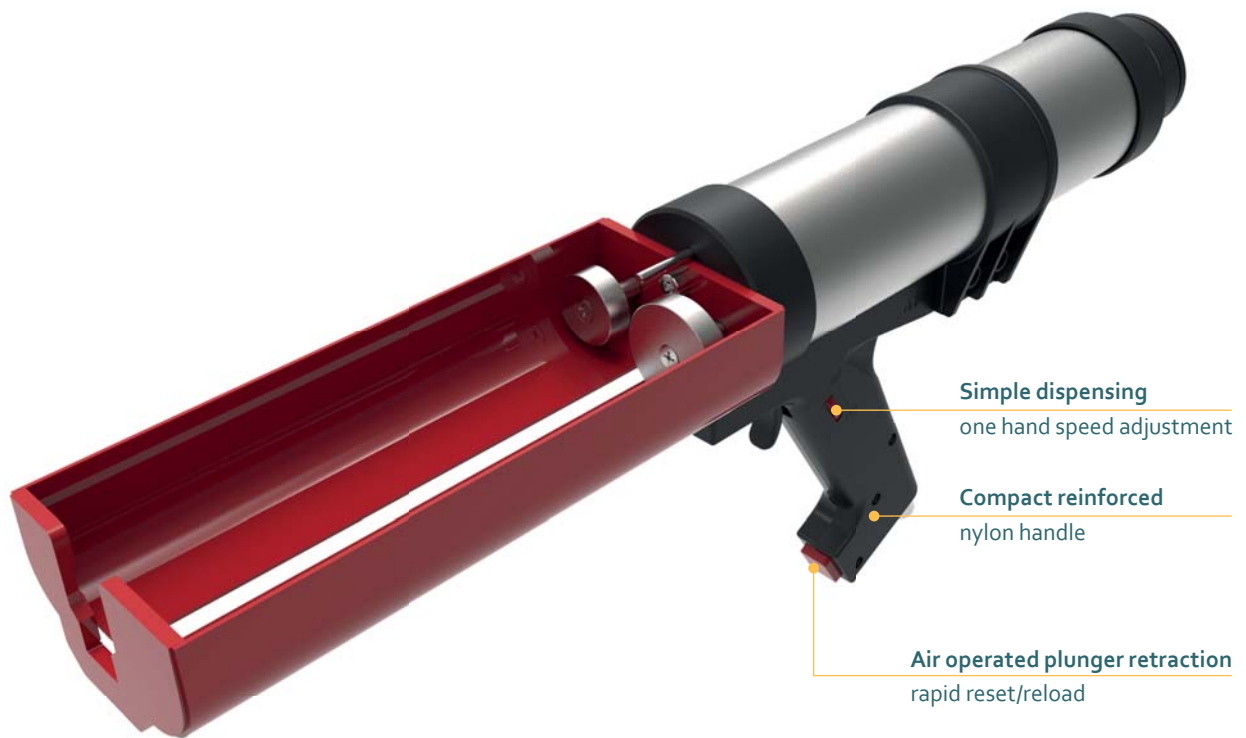

Model shown: TS459 LXS 450 mL

FEATURES

- Air operated plunger retraction
- One hand pressure adjustment
- Anti-drip function
- Long life technology
- Customization possible

BENEFITS

- Quick cartridge exchange
- Simple dispensing speed adjustment
- Clean application
- Precise working
- Customer labelling

APPLICATIONS



Chemical
Anchoring

PRODUCT BY RANGE



THE TS459 LXS 2-COMPONENT PNEUMATIC DISPENSERS QUICK CARTRIDGE EXCHANGE OFFERS EFFICIENT WORKING ACROSS ALL YOUR APPLICATIONS.

SPECIFICATIONS

- Lightweight: 2.69 kg / 5.9 lbs
- Cartridge Holder Length: 237 mm / 9.3 in
- Maximum Thrust: 2.7 kN
- Maximum Pneumatic Pressure: 8 bar / 116 psi
- Air Consumption: 40 litres/min
- Handle Material: Reinforced Nylon
- Cartridge Holder Material: Aluminum
- Frame Material: Steel
- Cartridge Capacity: 450 mL (15.8 oz)
- Cartridge Ratio: 2:1
- Viscosity: Medium/High
- Standard Color: Black/Red
- Customized versions on demand

DIMENSIONS

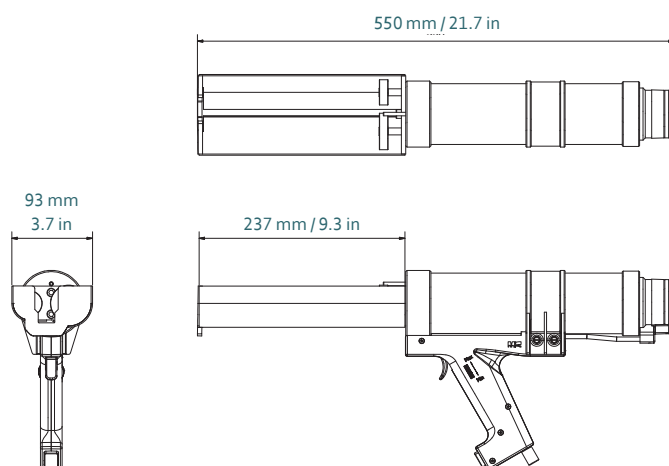

Part number	Article number	Packaging
DP2K 450-02-270-001	152515	1 per Box

MATCHING MIXPAC™ SIDE-BY-SIDE CARTRIDGES



J System
450 mL / 2:1 PP/PA

COMPATIBLE CARTRIDGES

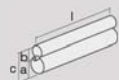

Plastic Cartridge
450 mL / 2:1 PP

2:1	mm	inch
l	215.0	8.46
a	Ø 46.5	Ø 1.83
b	Ø 33.2	Ø 1.31
c	86.0	3.39

CONVERSION KITS

MATCHING ACCESSORIES

TS459 XM

450 ML CARTRIDGE DISPENSER

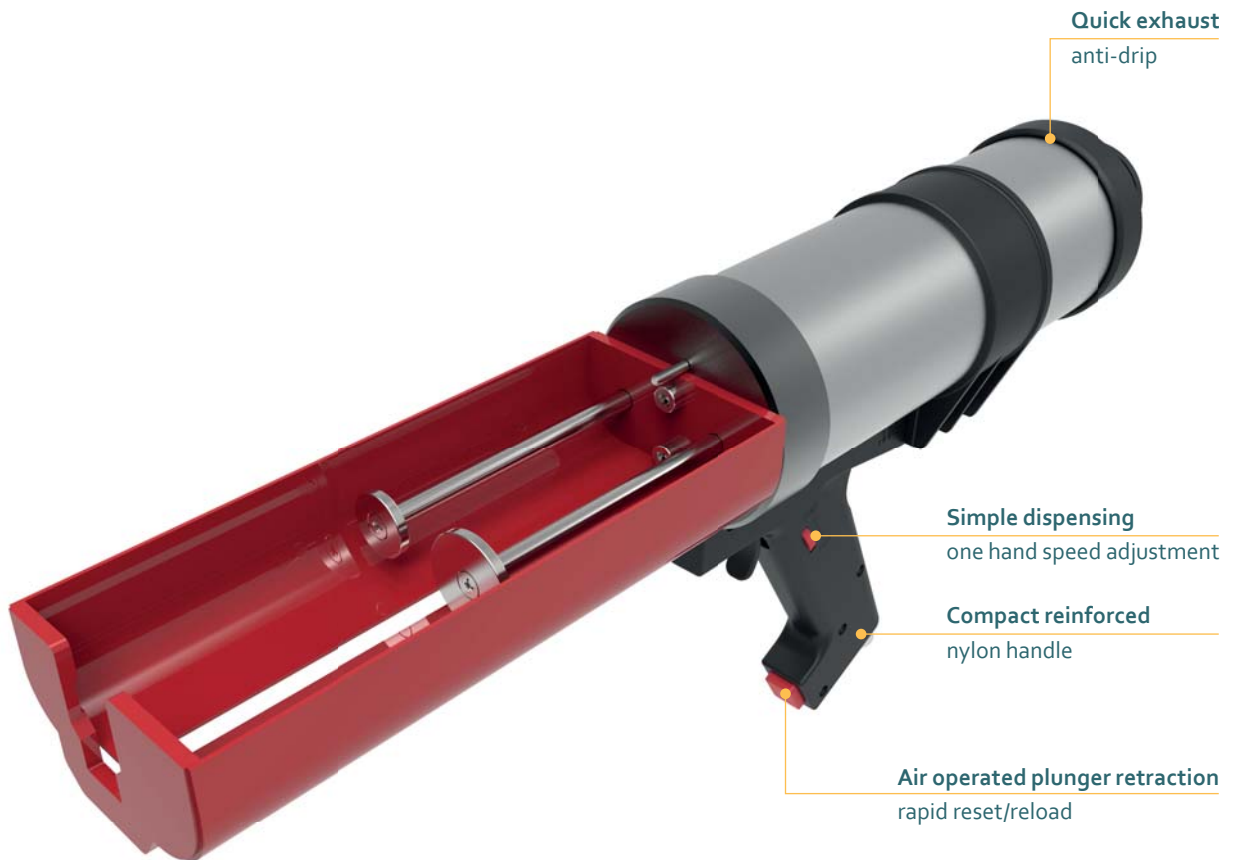

Model shown: TS459 XM 450 mL

FEATURES

- Air operated plunger retraction
- One hand pressure adjustment
- Anti-drip function
- Long life technology
- Customization possible

BENEFITS

- Quick cartridge exchange
- Simple dispensing speed adjustment
- Clean application
- Precise working
- Customer labelling

APPLICATIONS



PRODUCT BY RANGE



THE TS459 XM 2-COMPONENT PNEUMATIC DISPENSERS ONE-HANDED PRESSURE ADJUSTMENT ALLOWS FOR SIMPLE EFFECTIVE OPERATION WHILE THE ANTI-DRIP FUNCTION MAKES FOR EASY AND CLEAN DISPENSING.

SPECIFICATIONS

- Lightweight: 2.69 kg / 5.9 lbs
- Cartridge Holder Length: 218 mm / 8.6 in
- Maximum Thrust: 4.5 kN
- Maximum Pneumatic Pressure: 8 bar / 116 psi
- Air Consumption: 40 litres/min
- Handle Material: Reinforced Nylon
- Cartridge Holder Material: Aluminum
- Frame Material: Steel
- Cartridge Capacity: 450 mL (15.8 oz)
- Cartridge Ratio: 2:1
- Viscosity: Medium
- Standard Color: Black
- Customized versions on demand

DIMENSIONS

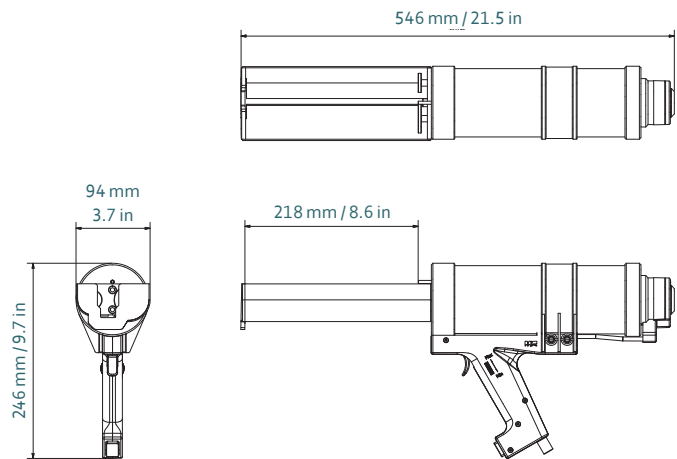

Part number	Article number	Packaging
DP2K 450-02-400-101	152516	1 per Box

MATCHING MIXPAC™ SIDE-BY-SIDE CARTRIDGES



J System
450 mL / 2:1 PP/PA

COMPATIBLE CARTRIDGES

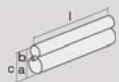

Plastic Cartridge
450 mL / 2:1 PP

2:1	mm	inch
l	215.0	8.46
a	Ø 46.5	Ø 1.83
b	Ø 33.2	Ø 1.31
c	86.0	3.39

CONVERSION KITS

MATCHING ACCESSORIES

TS444 KX

365/385/585 ML CARTRIDGE DISPENSER

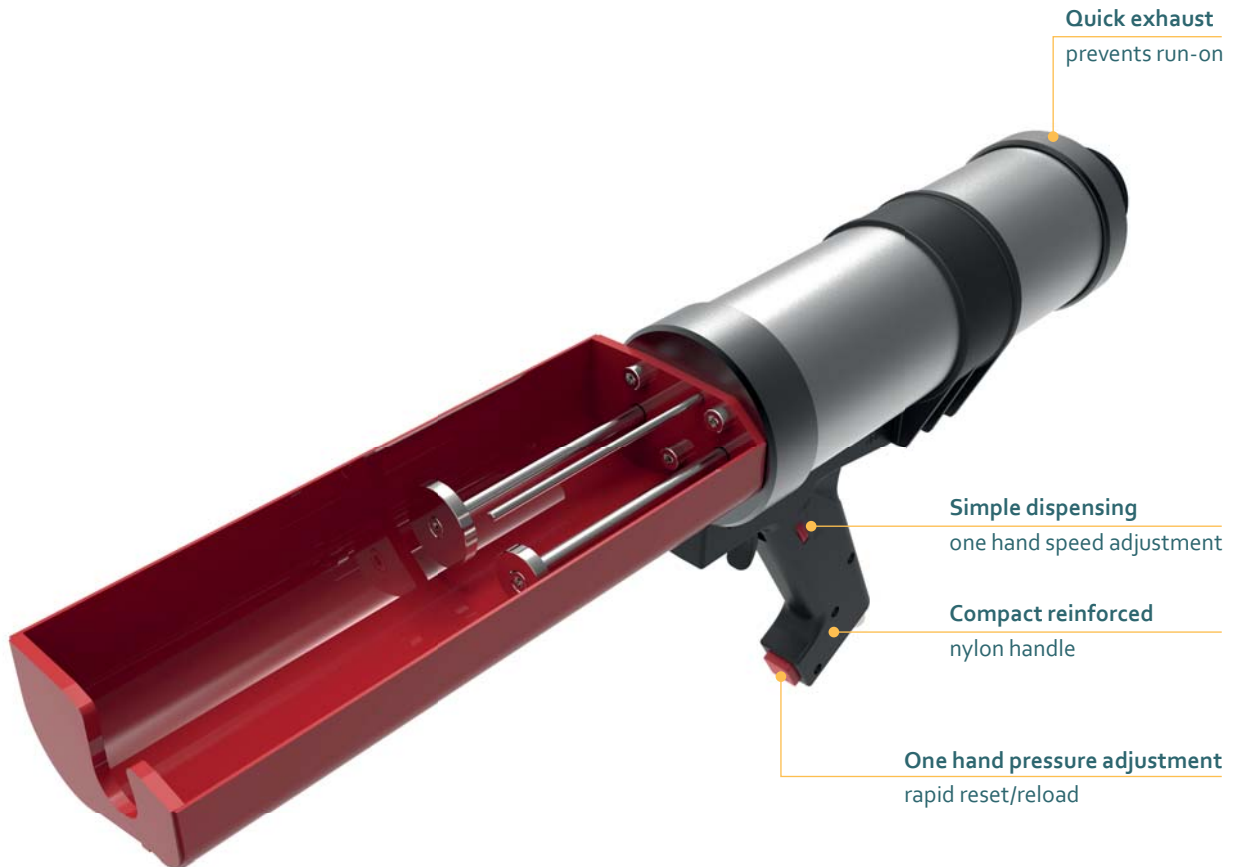

Model shown: TS444 KX 585 mL

FEATURES

- Quick exhaust
- Speed adjustment during operation
- Rapid reset/reload
- Customization possible

BENEFITS

- Prevents anti-drip
- Simple dispensing
- One hand pressure adjustment
- Customer labelling

APPLICATIONS



PRODUCT BY RANGE



TS444 KX

THE TS444 KX 2-COMPONENT PNEUMATIC DISPENSERS COMPACT REINFORCED NYLON HANDLE ALLOWS FOR SIMPLE EFFECTIVE OPERATION, WHILE THE QUICK EXHAUST VALVE PREVENTS MATERIAL ANTI-DRIP FOR EFFORTLESS DISPENSING.

SPECIFICATIONS

- Lightweight: 3.05 kg / 6.80 lbs
- Cartridge Holder Length: 278 mm / 11.0 in
- Maximum Thrust: 4 kN
- Maximum Pneumatic Pressure: 8 bar / 116 psi
- Air Consumption: 40 litres/min
- Handle Material: Reinforced Nylon
- Barrel Material: Aluminum
- Cartridge Holder Material: Steel
- Cartridge Capacity: 365 mL (12.8 oz), 385 mL (13.5 oz), 585 mL (20.6 oz)
- Cartridge Ratio: 3:1
- Viscosity: Medium
- Standard Color: Black/Red
- Customized versions on demand

DIMENSIONS

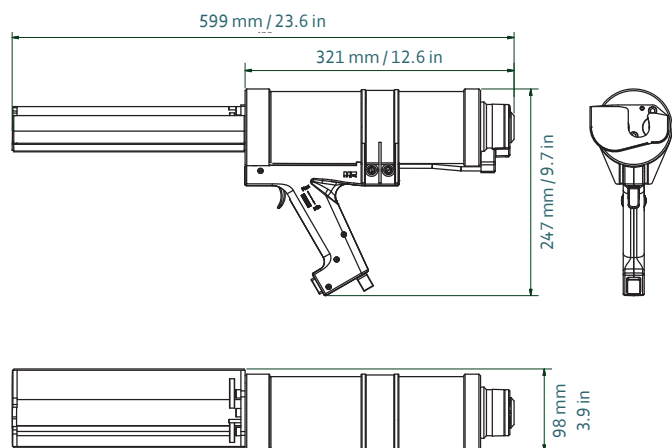

Part number	Article number	Packaging
DP2K 585-03-400-101	152487	1 per Box

MATCHING MIXPAC™ SIDE-BY-SIDE CARTRIDGES



J-System
365 mL / 3:1 PP



ecopaCC Cartridge
600 mL / 3:1

COMPATIBLE SIDE-BY-SIDE CARTRIDGES

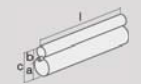

Plastic Cartridge
585 mL / 3:1

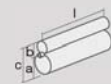

Plastic Cartridge
385 mL / 3:1 PP

3:1	mm	inch
l	244.0	9.61
a	Ø 54.4	Ø 2.14
b	Ø 32.6	Ø 1.28
c	90.0	3.54

3:1	mm	inch
l	171.0	6.73
a	Ø 54.4	Ø 2.14
b	Ø 32.6	Ø 1.28
c	90.0	3.54

CONVERSION KITS

MATCHING ACCESSORIES

TS447 X-625

580 ML CARTRIDGE DISPENSER

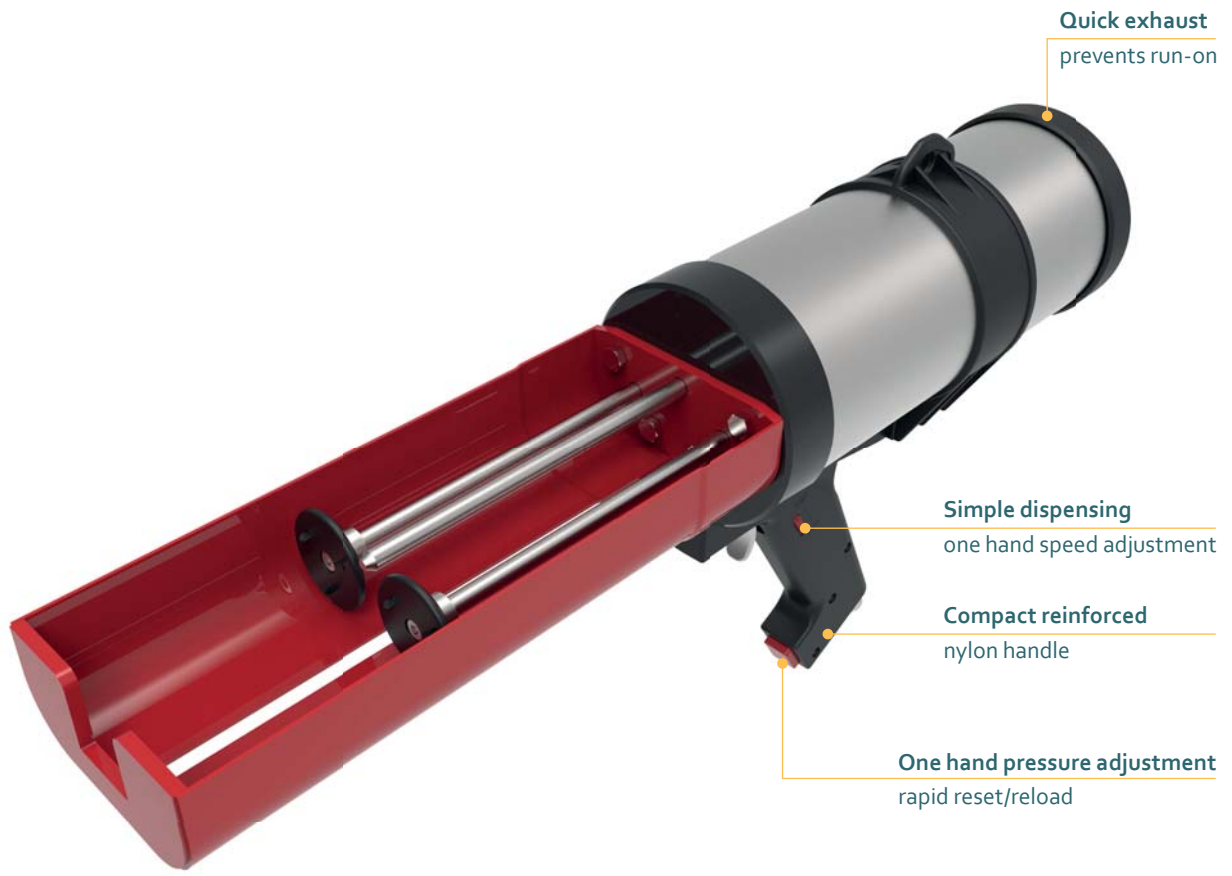

Model shown: TS447 X-625 580 mL

FEATURES

- Quick exhaust
- Speed adjustment during operation
- Rapid reset/reload
- Customization possible

BENEFITS

- Prevents anti-drip
- Simple dispensing
- One hand pressure adjustment
- Customer labelling

APPLICATIONS



PRODUCT BY RANGE



TS447 X-625

THE TS447 X-625 2-COMPONENT PNEUMATIC DISPENSER IS DESIGNED FOR USE WITH HIGH VISCOSITY SEALANTS AND ADHESIVES. A ONE-HANDED PRESSURE ADJUSTMENT ALLOWS FOR RAPID RESET AND RELOAD.

SPECIFICATIONS

- Lightweight: 3.53 kg / 7.87 lbs
- Cartridge Holder Length: 269 mm / 10.6 in
- Maximum Thrust: 6.25 kN
- Maximum Pneumatic Pressure: 8 bar / 116 psi
- Air Consumption: 40 litres/min
- Handle Material: Reinforced Nylon
- Cartridge Holder Material: Aluminum
- Frame Material: Steel
- Cartridge Capacity: 580 mL (20.4 oz)
- Cartridge Ratio: 1:1
- Viscosity: High
- Standard Color: Black/Red
- Customized versions on demand

DIMENSIONS

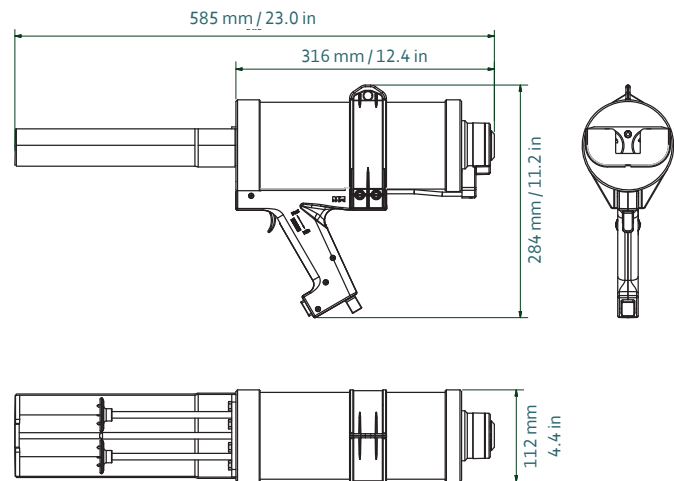

Part number	Article number	Packaging
DP2K 585-03-400-101	152387	1 per Box

MATCHING MIXPAC™ CARTRIDGES

COMPATIBLE SIDE-BY-SIDE CARTRIDGES

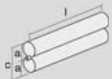

Aluminum Cartridge
580 mL / 1:1

1:1	mm	inch
l	238.0	9.37
a	Ø 47.0	Ø 1.8
c	98.0	3.8

CONVERSION KITS

MATCHING ACCESSORIES

TS488 X

600 ML CARTRIDGE DISPENSER

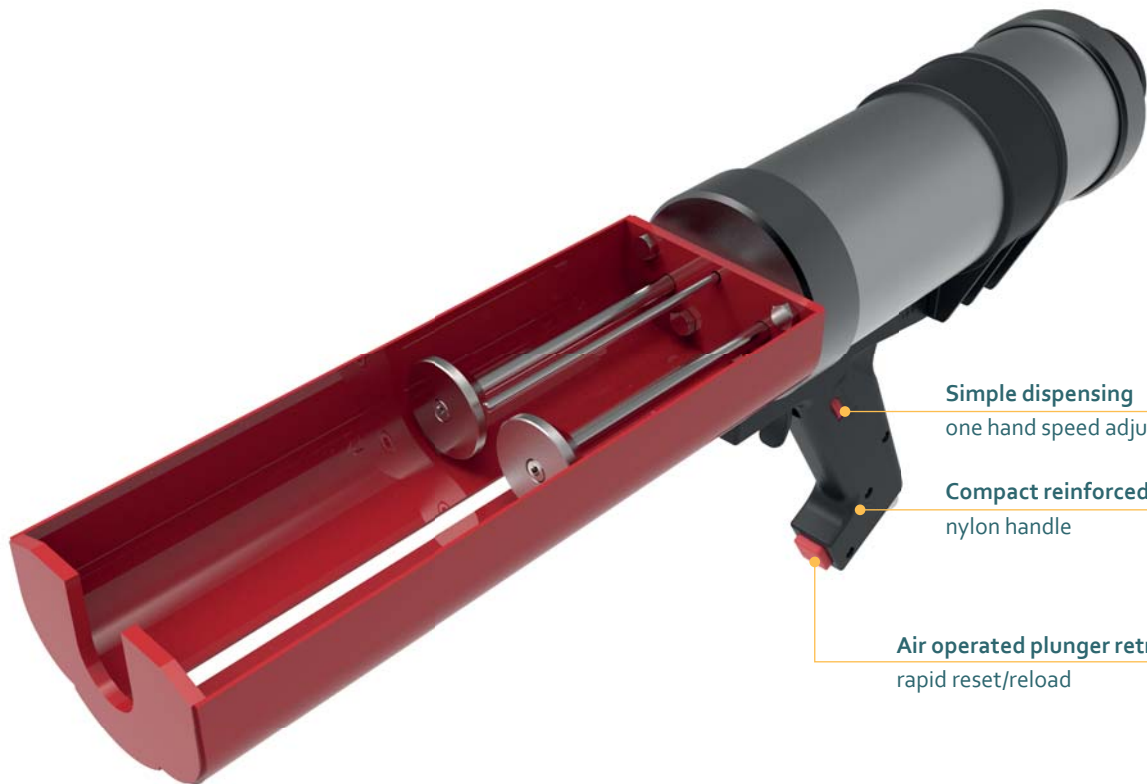

Simple dispensing
one hand speed adjustment

Compact reinforced
nylon handle

Air operated plunger retraction
rapid reset/reload

Model shown: TS488 X 600 mL

FEATURES

- Air operated plunger retraction
- One hand pressure adjustment
- Anti-drip function
- Long life technology
- Customization possible

BENEFITS

- Quick cartridge exchange
- Simple dispensing speed adjustment
- Clean application
- Precise working
- Customer labelling

APPLICATIONS



PRODUCT BY RANGE



THE TS488 X 2-COMPONENT PNEUMATIC DISPENSERS ONE-HANDED PRESSURE ADJUSTMENT ALLOWS FOR SIMPLE EFFECTIVE OPERATION. IN ADDITION, THE AIR OPERATED PLUNGER RETRACTION OFFERS RAPID RESET AND RELOAD.

SPECIFICATIONS

- Lightweight: 2.5 kg / 5.5 lbs
- Cartridge Holder Length: 286 mm / 11.2 in
- Maximum Thrust: 4 kN
- Maximum Pneumatic Pressure: 8 bar / 116 psi
- Air Consumption: 40 litres/min
- Handle Material: Reinforced Nylon
- Barrel Material: Aluminum
- Cartridge Holder Material: Steel
- Cartridge Capacity: 600 mL (21.1 oz)
- Cartridge Ratio: 1:1
- Viscosity: Medium
- Standard Color: Black/Red
- Customized versions on demand

DIMENSIONS

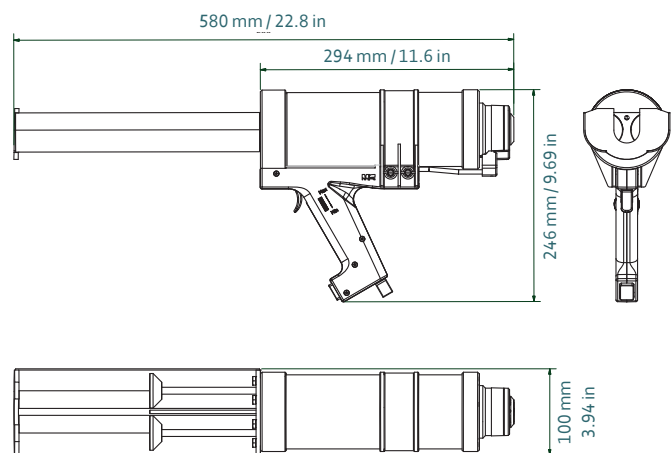

Part number	Article number	Packaging
DP2K 600-01-400-400	152899	1 per Box

MATCHING MIXPAC™ CARTRIDGES

COMPATIBLE SIDE-BY-SIDE CARTRIDGES

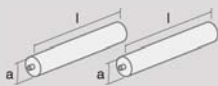

Aluminum Cartridge
620 mL (2 x 310 mL) / 1:1 AL

1:1	mm	inch
l	217.0	8.54
a	Ø 48.0	Ø 1.89
c	95.5	3.76

CONVERSION KITS

MATCHING ACCESSORIES

TS488 XM

600 ML CARTRIDGE DISPENSER

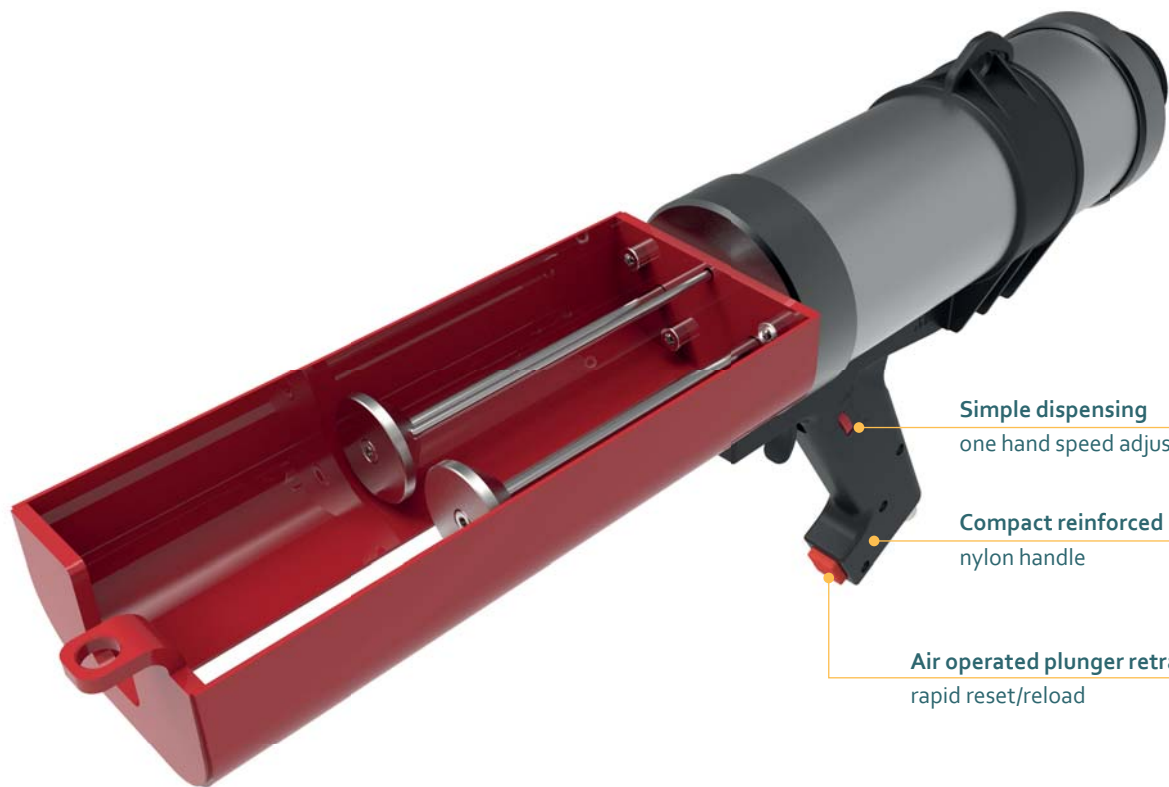

Simple dispensing
one hand speed adjustment

Compact reinforced
nylon handle

Air operated plunger retraction
rapid reset/reload

Model shown: TS488 XM 600 mL

FEATURES

- Air operated plunger retraction
- One hand pressure adjustment
- Anti-drip function
- Long life technology
- Customization possible

BENEFITS

- Quick cartridge exchange
- Simple dispensing speed adjustment
- Clean application
- Precise working
- Customer labelling

APPLICATIONS



PRODUCT BY RANGE



THE TS488 XM 2-COMPONENT PNEUMATIC DISPENSER IS DESIGNED FOR USE WITH MEDIUM VISCOSITY SEALANTS AND ADHESIVES WHILE THE ANTI-DRIP FUNCTION MAKES FOR EASY AND CLEAN DISPENSING.

SPECIFICATIONS

- Lightweight: 2.5 kg / 5.5 lbs
- Cartridge Holder Length: 270 mm / 10.6 in
- Maximum Thrust: 4 kN
- Maximum Pneumatic Pressure: 8 bar / 116 psi
- Air Consumption: 40 litres/min
- Handle Material: Reinforced Nylon
- Cartridge Holder Material: Aluminum
- Frame Material: Steel
- Cartridge Capacity: 600 mL (21.1 oz)
- Cartridge Ratio: 1:1
- Viscosity: Medium
- Standard Color: Black/Red
- Customized versions on demand

DIMENSIONS

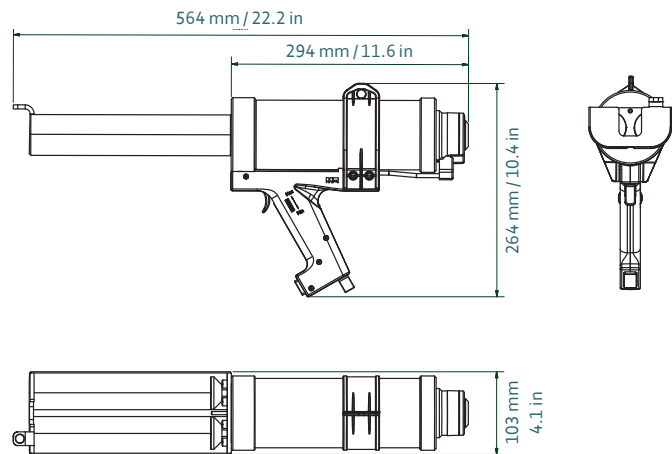

Part number	Article number	Packaging
DP2K 600-01-400-101	152352	1 per Box

MATCHING MIXPAC™ SIDE-BY-SIDE CARTRIDGES



J-System
600 mL / 1:1 PP



ecopaCC
600 mL / 1:1 PP/PA

COMPATIBLE CARTRIDGES

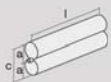

Plastic Cartridge
600 mL / 1:1 PP

1:1	mm	inch
l	215.0	8.46
a	Ø 49.3	Ø 1.94
c	98.5	3.88

CONVERSION KITS

MATCHING ACCESSORIES

TS493 X / TS493 XT

600 ML CARTRIDGE DISPENSER

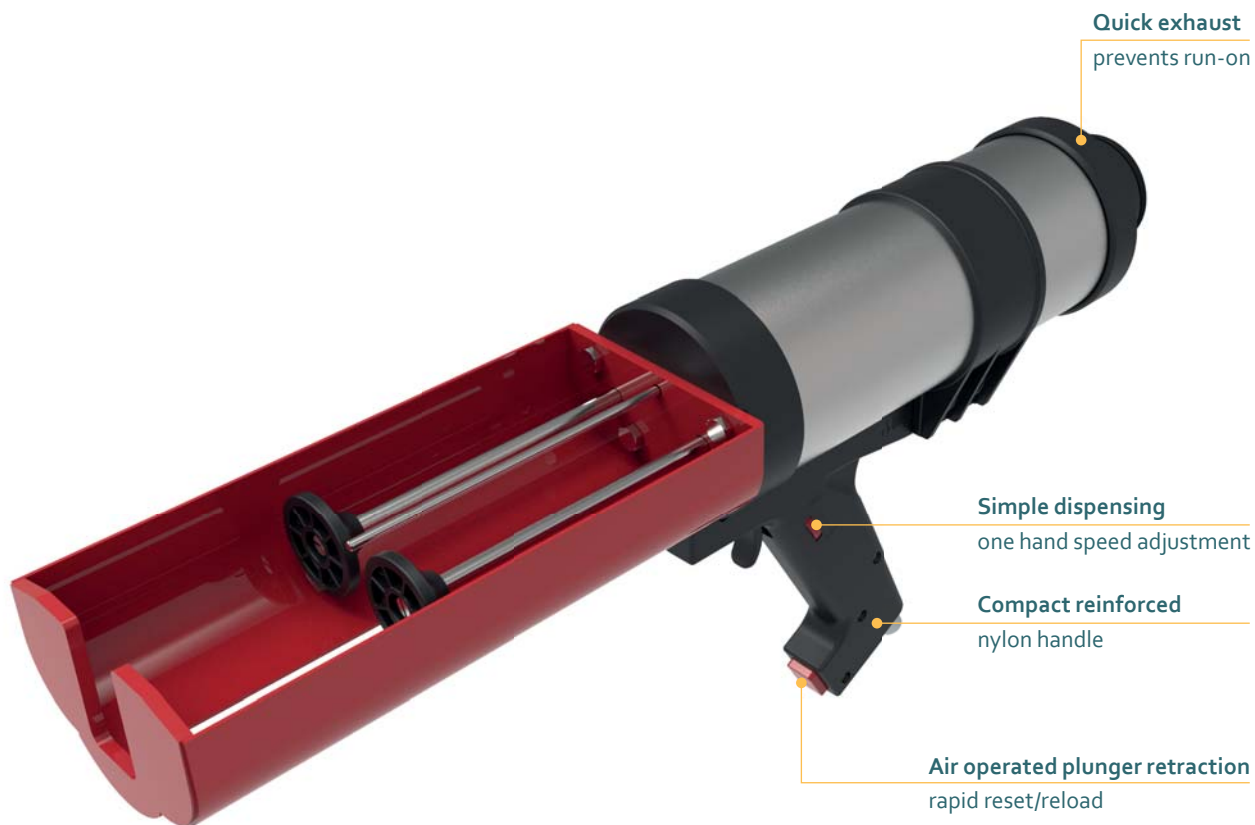

Model shown: TS493 X(T) 600 mL

FEATURES

- Air operated plunger retraction
- One hand pressure adjustment
- Anti-drip function
- Long life technology
- Customization possible

BENEFITS

- Quick cartridge exchange
- Simple dispensing speed adjustment
- Clean application
- Precise working
- Customer labelling

APPLICATIONS



PRODUCT BY RANGE



THE TS493 X(T) 2-COMPONENT PNEUMATIC DISPENSER ANTI-DRIP FUNCTION MAKES FOR EASY AND CLEAN DISPENSING. IN ADDITION, THE AIR OPERATED PLUNGER RETRACTION OFFERS RAPID RESET AND RELOAD.

SPECIFICATIONS

- Lightweight: 2.6 kg / 5.6 lbs
- Cartridge Holder Length: 235 mm / 9.3 in
- Maximum Thrust: 4 kN
- Maximum Pneumatic Pressure: 8 bar / 116 psi
- Air Consumption: 40 litres/min
- Handle Material: Reinforced Nylon
- Cartridge Holder Material: Aluminum
- Frame Material: Steel
- Cartridge Capacity: 600 mL (21.1 oz)
- Cartridge Ratio: 1:1
- Viscosity: Medium
- Standard Color: Black/Red
- Customized versions on demand

DIMENSIONS

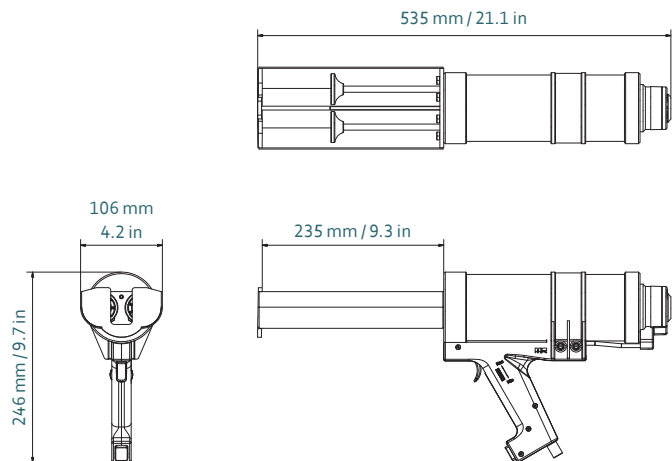

Part number	Article number	Packaging
DP2K 600-01-400-201	151790 TS493 X (620 mL)	1 per Box
DP2K 600-01-400-401	152883 TS493 XT (600 mL)	1 per Box

MATCHING MIXPAC™ CARTRIDGES

COMPATIBLE SIDE-BY-SIDE CARTRIDGES

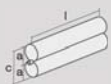

Plastic Cartridge
620 mL (2 x 310 mL) / 1:1 PP

1:1	mm	inch
l	217.0	8.54
a	Ø 48.0	Ø 1.89
c	95.5	3.76

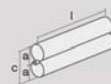

Plastic Cartridge
600 mL / 1:1 PP

1:1	mm	inch
l	215.0	8.46
a	Ø 49.0	Ø 1.93
c	99.0	3.9

CONVERSION KITS

MATCHING ACCESSORIES

TS471

1400 ML CARTRIDGE DISPENSER

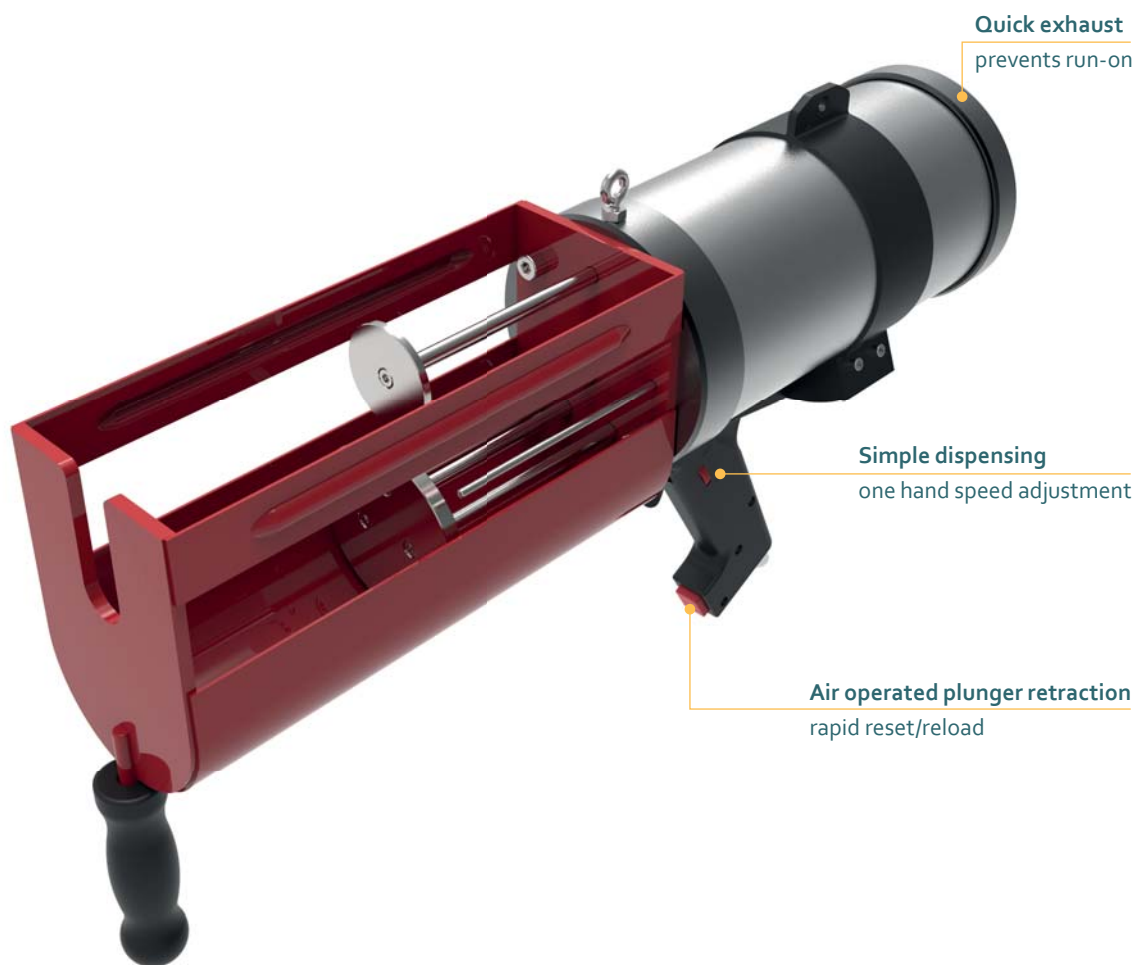

Model shown: TS471 1400 mL

FEATURES

- Quick exhaust
- Simple dispensing
- Air operated plunger retraction
- Customization possible

BENEFITS

- Prevents anti-drip
- One-hand speed adjustment
- Quick cartridge exchange
- Customer labelling

APPLICATIONS



PRODUCT BY RANGE



TS471

THE TS471 2-COMPONENT PNEUMATIC DISPENSERS AIR OPERATED PLUNGER RETRACTION OFFERS RAPID RESET AND RELOAD WHILE ANTI-DRIP FUNCTION MAKES FOR EASY AND CLEAN DISPENSING.

SPECIFICATIONS

- Lightweight: 3.95 kg / 8.8 lbs
- Cartridge Holder Length: 298 mm / 11.7 in
- Maximum Thrust: 8.3 kN
- Maximum Pneumatic Pressure: 8 bar / 116 psi
- Air Consumption: 40 litres/min
- Handle Material: Reinforced Nylon
- Cartridge Holder Material: Aluminum
- Frame Material: Steel
- Cartridge Capacity: 1400 mL (49.3 oz)
- Cartridge Ratio: 3:1
- Viscosity: Medium/High
- Standard Color: Black/Red
- Customized versions on demand

DIMENSIONS

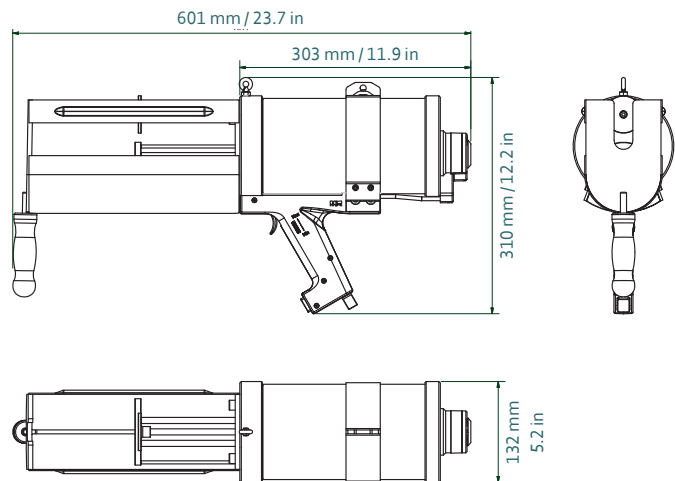

Part number	Article number	Packaging
DP2K 1400-03-830-001	153201	1 per Box

MATCHING MIXPAC™ CARTRIDGES

COMPATIBLE SIDE-BY-SIDE CARTRIDGES



Plastic Cartridge
1400 mL / 3:1





3:1	mm	inch
l	235.0	9.25
a	Ø 96.4	Ø 3.8
b	Ø 60.0	Ø 2.36
c	157.5	6.2

CONVERSION KITS

MATCHING ACCESSORIES

MK™ DISPENSER ACCESSORIES

MAKE THE MOST OF YOUR DISPENSER WITH THE FOLLOWING RANGE OF MK ACCESSORIES.

Name/Description	Part Number	Compatible with
Pistons		
 Piston for Cartridge	152549	TS493 X(T)
Battery		
 Bosch Professional Charger Universal battery charger for 18 V batteries.	163517 (EU) 165577 (UK) 165572 (US)	MK 2K B900 series
 Bosch Professional Battery Lithium-ion battery, 18 V 2.0 Ah.	175925 163515 (US)	MK 2K B900 series
General accessories		
 Shoulder strap	129031	

MK™ DISPENSER

WARRANTY STATEMENT

medmix offers a (2) year manufacturing warranty effective at the date of invoice.
medmix will repair or replace any product which examination proves to be a manufacture defect.

LIMITATIONS:

This warranty does not cover:

1. Repairs made or attempted by other than medmix UK Ltd. or Authorized Service Centre
2. Normal wear and tear
3. Misuse
4. Improper maintenance
5. Continued use after partial failure
6. Tools that have been modified or used with improper accessories

Should a problem develop while still under warranty, return the complete product to medmix UK Ltd. freight prepaid and insured. If inspection shows the problem has been caused by a defect in manufacture, all repairs, or a replacement will be made, at no charge and the product will be returned, transportation prepaid. No other warranty, written or verbal, is authorized.

The repair and replacement remedies described herein are exclusive. In no event shall medmix UK Ltd. be liable for any incidental, special, or consequential damages, including loss of profits, loss of use or loss of production.

This warranty is in lieu of all other warranties, expressed or implied including without limitation the implied warranties of merchantability and fitness for a particular purpose, which are expressly disclaimed.

DELIVERING INNOVATION. INSPIRING CONFIDENCE.

EUROPE

medmix Switzerland AG

Ruetistrasse 7

9469 Haag, Switzerland

Phone +41 81 414 70 00

sales.industry@medmix.com

www.medmix.swiss

USA, SOUTH AMERICA, CANADA AND MEXICO

medmix USA Inc.

8 Willow St.

Salem, NH 03079, USA

Phone +1 603 893 2727

sales.industry@medmix.com

www.medmix.swiss

UK AND IRELAND

medmix UK Ltd.

1 Tealgate, Charnham Park, Hungerford

Berkshire, RG17 0YT, United Kingdom

Phone: +44 (0)1488 647 800

sales.industry@medmix.com

www.coxdispensers.com

ASIA PACIFIC

medmix China Ltd.

68 Bei Dou Lu, Minhang Shanghai

200245, China

Phone: +86 21 6430 68 68

sales.industry@medmix.com

www.medmix.swiss



Legal Notice: This brochure is a general presentation. The information contained in this publication is believed to be accurate and reliable but is not to be construed as implying any warranty or guarantee of performance. We waive any liability and indemnity for effects resulting from its application. Please, contact us for a description of the warranties and guarantees offered with our products. Directions for use and safety will be given separately. All information herein is subject to change without notice.

© 2022 medmix Switzerland AG All rights reserved.

medmix is a trademark belonging to medmix AG, and MK is a trademark belonging to medmix Switzerland AG.